

Deanship of Graduate Studies

Al-Quds University

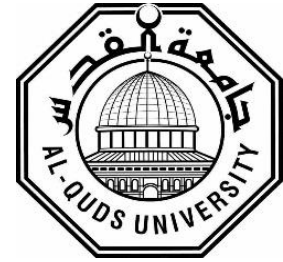

**Securing electricity needs from rooftop solar PV systems: A
case study of three schools in Beit Fajjar-Bethlehem-
Palestine**

Ali Yousef Mohammed Taqatqa

M.Sc. Thesis

Jerusalem-Palestine

1445 / 2023

**Securing electricity needs from rooftop solar PV systems: A
case study of three schools in Beit Fajjar-Bethlehem-
Palestine**

Prepared by:

Ali Yousef Mohammed Taqatqa

B.Sc.: Physics, Al-Quds University, Palestine

Supervisor: Dr. Husain Alsamamra

Physics Department, Al-Quds University, Palestine

**A thesis submitted in partial fulfillment of requirements for the degree of master
of physics, Al-Quds University**

1445/2023

Al-Quds University
Deanship of Graduate Studies
Physics Department

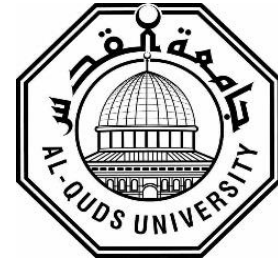

Thesis approval

**Securing electricity needs from rooftop solar PV systems: A
case study of three schools in Beit Fajjar-Bethlehem-
Palestine**

Prepared by: Ali Yousef Mohammed Taqatqa

Registration No.: 21910073

Supervisor: Dr. Husain Alsamamra

Master thesis submitted and accepted, Date: 23 / 12 / 2023

The names and signatures of the examining committee members as follows:

1- Head of Committee: Dr. Husain Alsamamra

Signature:

2- Internal Examiner: Prof. Dr. Musa Abu Teir

Signature:

3- External Examiner: Dr. Ishaq Musa

Signature:

Jerusalem-Palestine

1445 / 2023

Dedication

To my parents

To my sisters

To my brother, his wife and their daughter Suad

To my friends

Declaration:

I certify that this thesis submitted for the degree of master is the result of my own research, except where otherwise acknowledged, and that this thesis, neither in whole or in part, has been previously submitted for any degree to any other university or institution.

The work was done under the supervision of Dr. Husain Alsamamra from physics department-Al-Quds University.

Name: Ali Yousef Mohammed Taqatqa

Signed:

A handwritten signature in blue ink, appearing to be 'Ali Yousef Mohammed Taqatqa', written over a horizontal line.

Date: 23 / 12 / 2023

Acknowledgement

I would like to express my sincere thanks to my instructor and supervisor Dr. Husain Alsamamra for his guidance, assistance, advice and constant encouragement during research.

My deepest gratitude to my teachers; the staff of physics Department at Al-Quds University for their continuous support during my master's study.

Abstract

In Palestine the energy sector suffers due to the various policies of the Israeli occupation, and the energy sector in Palestine is considered expensive as a result of the dependence of the industrial sector in Palestine directly on electricity, so it is necessary to resort to sources of renewable energy as a new source of energy.

Solar energy systems are one of the most important renewable energy sources in the world, and the countries of the world today seek to exploit this method in securing their energy needs. To exploit solar energy must be available the spaces on which solar projects should be placed, hence the idea of this study in exploiting the roofs of almost empty schools in the generation of electricity through solar photovoltaic projects, because schools close their doors about 180 days a year, and have a period of working a day with a maximum of 7 hours, as well as the low energy consumption, all of these stimulate the exploitation of these spaces available on school roofs to generate solar energy.

In order to study the feasibility of exploiting the roofs of buildings to generate electrical energy, in this study, PVSyst software was used to build and design three photovoltaic systems on the roofs of three schools of different area and amount of consumption, and then calculate the income and payback period. The total area used in the three projects combined was about 901 m², the total number of panels used was 345 panels, and the capacity of the three systems 189.75 Kw, so the annual production 314681 kwh. From the electricity company's readings, it was found that the three schools consumes an amount of electricity amounting to 39401 kwh, so the annual surplus amount from the three schools is about 268653 kwh, and its annual selling price reaches 150445.68 NIS. The number of schools in Palestine 3075 When this project is implemented on the roofs of these schools, they will produce 322.54 Gwh, which represents 4.98% of the annual consumption of electricity in Palestine, in addition to the schools' energy consumption, which represents 0.6% of the annual consumption. The total cost of the project will reach 816 million NIS with a payback period of about 5 years, and the total annual income from selling the surplus electricity for schools will be 154 million NIS. This will help reduce the bill for purchasing electricity from Israel, as it will save the Palestinian treasury an amount of 150.5 million NIS after about 5 years.

Table of contents:

Content	Page
Declaration	I
Acknowledgement	II
Abstract	III
Table of contents	IV
List of figures	V
List of Tables	VII
List of Abbreviations	IX
List of Symbols	X
Chapter one: Introduction and Literature Review	1
1.1 Introduction	1
1.2 Solar Radiation in Palestine	3
1.3 Background	14
1.4 Literature review	15
1.5 Statement of the problem	18
1.6 Justification	19
Chapter Two: Theoretical frame work	20
2.1 PV system	20
2.1.1 types of PV system	20
2.1.2 Comparison between on-grid and off grid PV systems	22
2.1.3 component of On grid system	23
2.2 Methodology	26
2.2.1 Study area	26
2.2.2 Beit Fajjar location	28
2.2.3 The selected schools data	29
2.2.4 Working phases and computer tools	33
Chapter Three: Results and Discussion	34
3.1 Introduction	34
3.2 PV systems and revenues.	34
3.2.1 Al-Tahrir Boys School Result.	35
3.2.2 Beit Fajjar Secondary Girls School Result.	48
3.2.3 Al-sakra primary school Result.	63
Chapter Four: Conclusions and Future Work	77
4.1 Conclusions	77
4.2 Future work	79
References	82
المخلص	86

List of Figures

Figure No.	Description	Page
Figure 1.1	Annual sum of irradiance for surface inclined to the south with 270 degree, period 1994-2013.	5
Figure 1.2	Monthly average of solar radiation in different cities in West Bank 2010.	6
Figure 1.3	Monthly average of solar radiation in Gaza 1989-2002.	6
Figure 1.4	Annual average air temperature at 2 m height, period 1991-2010.	7
Figure 1.5	Monthly wind speed in different cities in West Bank in year 2013.	10
Figure 1.6	Clearness index % in Palestinian areas.	11
Figure 1.7	Annual PV electricity output from an open space tilted due south with 270 with a nominal peak of 1 kW.	13
Figure 2.1	Configuration for standalone system.	20
Figure 2.2	Configuration of grid tied system.	21
Figure 2.3	configuration of hybrid solar system.	22
Figure 2.4	Map of West Bank and Gaza.	28
Figure 2.5	Map of Beit Fajjar .	29
Figure 2.6	Al-Tahrir Boys School.	30
Figure 2.7	Beit Fajjar Secondary Girls School.	31
Figure 2.8	Al-sakra primary school.	32
Figure 3.1	Electricity consumption and financial cost (kWh and NIS) for Al-Tahrir Boys School .	36
Figure 3.2	Solar insolation (KWh/m ² .day) in Beit Fajjar.	37
Figure 3.3	distribution of photovoltaic panels on the roof of a Al-Tahrir Boys School.	43
Figure 3.4	Perspective of the PV-field and surrounding shading scene on the roof of a Al-Tahrir Boys School.	43
Figure 3.5	Monthly AC Production for Al-Tahrir Boys School.	44
Figure 3.6	Monthly AC Production / Consumption Value (KWh)for Al-Tahrir Boys School.	45

Figure 3.7	Monthly The AC surplus value (KWh)for Al-Tahrir Boys School.	46
Figure 3.8	Total income over 20 years for Al-Tahrir Boys School.	47
Figure 3.9	Electricity consumption and financial cost (kWh and NIS) for Beit Fajjar Secondary Girls School.	49
Figure 3.10	Solar insolation (KWh/m2.day) in Beit Fajjar	50
Figure 3.11	distribution of photovoltaic panels on the roof of a Beit Fajjar Secondary Girls School.	58
Figure 3.12	Perspective of the PV-field and surrounding shading scene on the roof of a Beit Fajjar Secondary Girls School.	58
Figure 3.13	Monthly AC Production for Beit Fajjar Secondary Girls School.	59
Figure 3.14	Monthly AC Production / Consumption Value (KWh)for Beit Fajjar Secondary Girls School.	60
Figure 3.15	Monthly The AC surplus value (KWh)for Beit Fajjar Secondary Girls School.	61
Figure 3.16	Total income over 20 years for Beit Fajjar Secondary Girls School.	62
Figure 3.17	Electricity consumption and financial cost (kWh and NIS) for Al-sakra primary school .	64
Figure 3.18	Solar insolation (KWh/m2.day) in Beit Fajjar	65
Figure 3.19	distribution of photovoltaic panels on the roof of a Al-sakra primary school .	71
Figure 3.20	Perspective of the PV-field and surrounding shading scene on the roof of a Al-sakra primary school.	71
Figure 3.21	Monthly AC Production for Al-sakra primary school .	72
Figure 3.22	Monthly AC Production / Consumption Value (KWh)for Al-sakra primary school .	73
Figure 3.23	Monthly The AC surplus value (KWh)for Al-sakra primary school.	74
Figure 3.24	Total income over 20 years for Al-sakra primary school .	75

List of Tables

Table No.	Description	Page
Table 1.1	Annual sum of irradiance for surface inclined to the south with 270 degree, period 1994-2013.	7
Table 1.2	Monthly average of solar radiation in different cities in West Bank 2010.	9
Table 1.3	Monthly average of solar radiation in Gaza 1989-2002.	10
Table 1.4	Annual average air temperature at 2 m height, period 1991-2010.	14
Table 2.1	Monthly wind speed in different cities in West Bank in year 2013.	24
Table 2.2	Clearness index % in Palestinian areas.	29
Table 2.3	Annual PV electricity output from an open space tilted due south with 270 with a nominal peak of 1 kW.	30
Table 2.4	Configuration for standalone system.	31
Table 2.5	Configuration of grid tied system.	32
Table 3.1	Al-Tahrir Boys School building specifications	35
Table 3.2	Electricity consumption and financial cost (kWh and NIS) for Al-Tahrir Boys School .	35
Table 3.3	Monthly global solar insolation at Bethlehem-Beit Fajjar.	36
Table 3.4	information entered into PVsyst software for Al-Tahrir Boys School	39
Table 3.5	Specification of solar PV modules Table for Al-Tahrir Boys School.	39
Table 3.6	Characteristics of the first Inverter for Al-Tahrir Boys School.	40
Table 3.7	Characteristics of the second Inverter for Al-Tahrir Boys School	41
Table 3.8	First and second Inverter String for Al-Tahrir Boys School	43
Table 3.9	Monthly AC Production for Al-Tahrir Boys School.	44
Table 3.10	Monthly The AC surplus value (KWh)for Al-Tahrir Boys School.	46
Table 3.11	Beit Fajjar Secondary Girls School building specifications	48

Table 3.12	Electricity consumption and financial cost (kWh and NIS) for Beit Fajjar Secondary Girls School.	49
Table 3.13	Monthly global solar insolation at Bethlehem-Beit Fajjar.	50
Table 3.14	information entered into PVsyst software for Beit Fajjar Secondary Girls School.	52
Table 3.15	Specification of solar PV modules Table for Beit Fajjar Secondary Girls School.	53
Table 3.16	Characteristics of the first Inverter for Beit Fajjar Se. School.	54
Table 3.17	Characteristics of the second Inverter for Beit Fajjar Secondary Girls School.	55
Table 3.18	First and second Inverter String for Beit Fajjar Secondary Girls School	57
Table 3.19	Monthly AC Production for Beit Fajjar Secondary Girls School.	59
Table 3.20	Monthly The AC surplus value (KWh)for Beit Fajjar Secondary Girls School.	61
Table 3.21	Al-sakra primary school building specifications.	63
Table 3.22	Electricity consumption and financial cost (kWh and NIS) for Al-sakra primary school .	64
Table 3.23	Monthly global solar insolation at Bethlehem-Beit Fajjar.	65
Table 3.24	information entered into PVsyst software for Al-sakra primary school	67
Table 3.25	Specification of solar PV modules Table for Al-sakra primary school .	68
Table 3.26	Characteristics of the Inverter for Al-sakra primary school .	69
Table 3.27	Inverter String for Al-sakra primary school .	70
Table 3.28	Monthly AC Production for Al-sakra primary school	73
Table 3.29	Monthly The AC surplus value (KWh)for Al-sakra primary school .	74
Table 4.1	Summary of the results for each of the three systems	78

List of Abbreviations

Abbreviation	Meaning
PT	Palestinian Territories.
PCBS	Palestinian Central Bureau of Statistics.
PENRA	Palestinian Energy & Natural Resources Authority
USD	United States dollar.
NIS	New Israeli shekel.
PV	photovoltaic
PVsyst	PVsyst software.
GHI	Global horizontal radiation.
GTI	Global Tilt Irradiance.
DNI	Direct Normal Radiation.
AC	Alternative Current.
DC	Direct Current.
Kwh	Kilo Watt hour.
Gwh	Giga Watt hour.
MPPT	Maximum Power Point Tracking.
Vdc	Volts direct current.

List of Symbols

Symbol	Meaning
p_{\max}	Maximum power
I_{mp}	Current at Maximum power
V_{mp}	Voltage at Maximum power
I_{sc}	Short Circuit Current
V_{oc}	Open Circuit Voltage
W_p	peak Watt
V_{Mpp}	The voltage at Maximum Power
PR	performance ratio
m	meter
mm	Millimeter
m^2	Square meters
kg	Kilogram
A	Ampere
V	Volt
W	Watt

Chapter One

Introduction and Literature Review

1.1 Introduction

These days, the world expand rapidly and the population increasing around the world, so the energy need increasing fast too. Moreover, the damage to the ozone layer, which caused global warming due to the use of oil and its products in power generation, makes us reconsider the sources that should be used in generating energy [1]. Today the world tends to use renewable and green energy sources in order to generate energy to preserve the environment [2][3].

The energy sector in Palestine is considered one of the most complex energy systems in the region, and the main reason for this is the Israeli occupation, which limits and prevents the import of energy from neighboring Arab countries[4], and imposes a blockade on both the West Bank and Gaza Strip, the West Bank is divided into areas A, B, C and Gaza Strip besieged from 2007, and Because the industrial sector in Palestine depends on electricity to operate different production lines, electricity prices in Palestine are high [5], but in any case Palestine is exposed to nearly 3000 solar hours during the year, Solar radiation ranges in Palestine from 5.4 kWh/m² day to 6.0 kWh/m² [6].

But we must not forget that renewable energy sources such as solar energy, wind energy and others need large areas to become effective, hence the idea of this study by exploiting unused and wasted spaces to become a place for energy generation. Here in Palestine, the trend to renewable energy sources started about 16 years ago [7], but they are still weak due to the occupation policies that prevent the residents of Palestine from exploiting the resources as required [8]. According to the Palestinian Central Bureau of Statistics in 2019, Palestine consumed about 6213 Giga watt hour of electricity, and about 965 tons of oil equivalent of Oil derivatives and 197 tons of oil equivalent of energy from renewable energy [9].

Along the years, the schools closed their doors more than 180 days every year, moreover the schools open 7 hours maximum every day, during 2020 and 2021, schools were closed even further as a result of the Corona virus pandemic. . The roof of the schools are almost empty, so it is important to think of using that space over the roof to

invest in solar energy, so it may be useful, were the energy produced by the solar cells may be more than the energy consumed in the school all over the year, and think of the huge number of the schools in Palestine. Which is 3,074 schools in the Gaza strip and West-bank [10].

According to the Palestinian Central Bureau of Statistics (PCBS) in 2020, there are 3,074 schools in the West-bank and Gaza strip [11], these schools closed their doors more than 180 days of the year. Which in the Directorate of Education of Bethlehem the schools were divided into three classes according to the size of the school depending on the number of students and the size of the building, small, medium and large schools. Were the small schools have a roof space of 300 square meters, the medium 450 square meters and the large schools have a roof space of 750 square meters. These schools consume electricity at a different monthly summer consumption rate than in the winter period, as the average summer monthly consumption for small schools is 300 KWh, 400 KWh for medium and 500 KWh for large schools. As for the winter consumption rate, it is 350 KWh for small schools, 450 KWh for medium and 550 KWh for large schools [12]

According to the (PCBS) in 2019, Palestine consumed 6213 GWh in 2019 [6], and if we calculate the average of the schools monthly consumption to find the annual school consumption then multiply it by the number of schools in Palestine it will be about 16.6 GWh every year, which means that schools consume 0.3% of the total annual electricity consumption in Palestine. Studies added that the annual rate of solar radiation in Palestine is $5.94 \text{ KWh} / \text{m}^2 / \text{day}$. As the number of sunshine hours in Palestine exceeds 3,000 hours per year [13] [14] [15].

So, this project will study the effectiveness of using school's roofs to install solar cells to produce energy to serve the schools and the surplus will be returned to the electrical grid.

1.2 Solar Radiation in Palestine

Solar energy reaches the Earth in the form of electromagnetic radiation, similar to radio waves, but in a different frequency range. Available solar energy is often expressed in units of energy per hour per unit area, i.e. watts per square meter (W/m^2). The amount of energy available from the Sun outside the Earth's atmosphere is approximately $1,367.7 \text{ W}/\text{m}^2$; That's almost as much as a high-power hair dryer for every square foot of sunlight. Some of the sun's energy is absorbed as it passes through the Earth's atmosphere. Consequently, on a clear day the amount of solar energy available to the sun on the Earth's surface is typically $1000 \text{ W}/\text{m}^2$.

The available solar energy depends primarily on the height of the sun in the sky and the current cloud cover. The amount of solar energy available monthly or annually also depends on the location. In addition, the usable solar energy depends on the available solar energy, other weather conditions, the technology used and the application [16].

Palestine lacks any kind of fossil energy source. Most of the energy needed for industrial and other applications is imported from other countries. Fossil energy sources are considered very expensive sources from an economic and environmental point of view.

Solar power can be used in both large-scale applications and smaller systems for the home. Business and industry can diversify their energy sources, improve efficiency and save money by choosing solar technology for heating and cooling, industrial processes, electric heating and water. Homeowners can also use solar technology for heating, cooling and hot water, and can even generate enough electricity to operate "off the grid" or sell excess electricity to utilities, depending on local programs. Using solar heating and passive daylighting design strategies can help homes and commercial buildings operate more efficiently and make them welcoming and comfortable places better to live and work [17].

Palestine received relatively high quality solar energy throughout the year. Our goal is to study whether we can predict solar energy as an economical and reliable source of energy in the future. To what extent is the future strategic planning for the energy sector. Harnessing solar energy fundamentally depends on reliable recorded data on solar radiation. Just as any investment plan requires sufficient data to evaluate the risks and

outcomes of that investment, solar radiation data is considered the foundation of the operational process. Locations with the potential to exploit solar energy must have reliable solar radiation measurement data. This can be used to evaluate the investment and predict the site's energy performance [18].

The types of solar radiation considered are [19]:

1. Global horizontal radiation (GHI): sum of direct and diffuse radiation on a horizontal unit surface.
2. Global Tilt Irradiance (GTI): The sum of direct and diffuse radiation in the area of the tilted unit. Each angle of inclination corresponds to a GTI number.
3. Direct Normal Radiation (DNI): The total direct radiation intensity over a unit area that is always oriented perpendicular to the Sun and its position in the sky

When investing in photovoltaic modules, the GTI is taken into account in the inclination angle of the proposed module, which is very often considered as the elevation angle [20]. For solar reconciliation applications; It is necessary to take into account the value of direct normal radiation (DNI) [21]. Therefore, it is important to determine which application to use to select the appropriate data for evaluation.

Palestine can be divided into three solar zones based on global solar irradiance (GHI), as explained in Figure 2 [22]:

A. Areas with high radiation intensity: These are areas where the radiation intensity exceeds 2300 kWh/m². Year, are marked in red in "Figure (1.2)" and mainly affect the mountainous regions of Jerusalem, Ramallah, Bethlehem and Hebron. With the exception of the coastal areas of Gaza.

B. Average illuminance zones: These zones have GHI values between 2,200 and 2,300 kWh/m². year, are marked in brown in "Figure (1.2)" and cover mainly the Jordan Valley, Jericho, Tubas and other areas in the north-central West Bank.

C. Low lighting areas: These areas have GHI values of less than 2,200 kWh/m². year, are marked in brown in "Figure (1.1)" and mainly cover Jenin, Qalqilya, Tulkarim and other areas in the western West Bank.

These values were obtained from SOLARGIS [24], which provides global radiation intensity data via satellites for the period 1994-2013. It is obvious that the GHI values exceed 1900 kWh/m^2 . For one year, DNI values for most of Palestine are above 2000 kWh/m^2 . One year for most areas. These values show that the use of solar energy is possible in Palestine. It is important to note that the values provided have a margin of error. $4.0 - 9.0\%$ for global horizontal radiation (GHI), $5.0 - 10.0\%$ for inclined global direct radiation (GTI) and $10.0-15.0\%$ for normal direct radiation (DNI) [24].

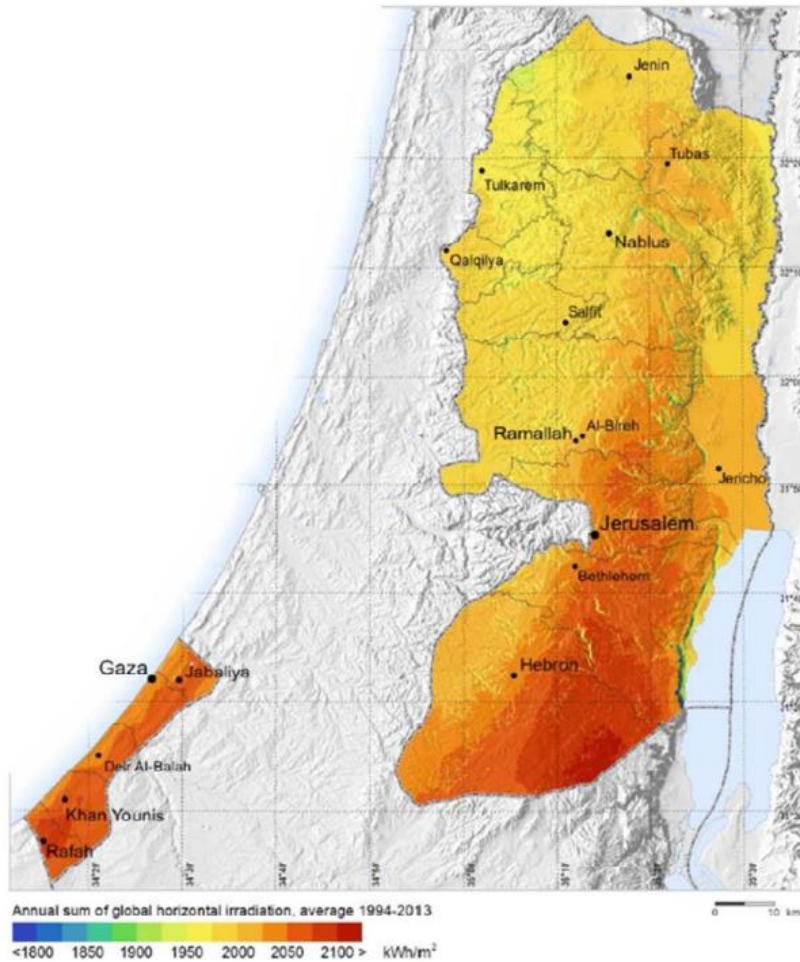

Fig. (1.1): Annual sum of irradiance for surface inclined to the south with 270 degree, period 1994-2013 [23].

Various inquire about considers have investigated sun oriented irradiance information in Palestine. In a ponder conducted by Alaydi [25] centering on sun oriented information in Gaza, it was watched that sun oriented irradiance information shows a steady design and does not show noteworthy year-to-year varieties. This proposes that sun based information stay generally steady, and the yearly vitality surrender is impossible to experience significant variances. Alsamamra [26] utilized measurable strategies to make a direct equation for modeling solar irradiance information in

Hebron. This equation can be utilized as an input work in vitality result recreations, encouraging more exact forecasts. Qassrawi and colleagues [27] carried out investigate in which they utilized neural systems to estimate long term execution of photovoltaic (PV) boards based on verifiable surrender information. Hussein and colleagues [28] carried out an investigation extend pointed at making observational models for the forecast of sun powered irradiance on a worldwide scale inside the Gaza Strip.

According to data from the Palestinian Energy and Natural Resources Authority (PENRA), the average Global Horizontal Irradiance (GHI) in Palestine stands at 5.4 kWh/m².day. This GHI figure fluctuates across different regions and throughout the year, with the lowest average value recorded in December at 2.63 kWh/m².day and the highest in June at 8.4 kWh/m².day. Palestine enjoys approximately 3000 hours of sunshine each year [22]. Figure (1.2) and figure (1.3) show the average values of GHI for some Palestinian cities as follows:

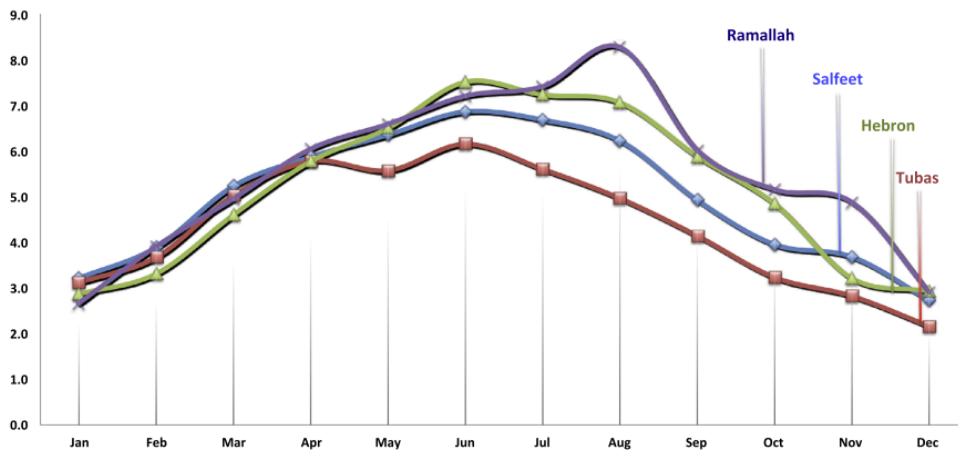

Fig. (1.2). Monthly average of solar radiation in different cities in West Bank 2010 [29].

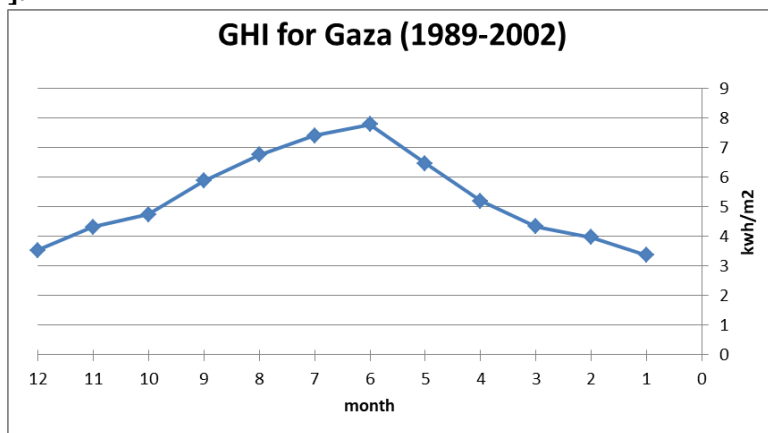

Fig. (1.3). Monthly average of solar radiation in Gaza 1989-2002 [30].

Temperature Effect:

Discuss temperature could be a basic figure to consider when tackling sun based vitality, affecting both photovoltaic boards and warm sun oriented boards with concentrators. Hoisted discuss temperatures can lead to diminished effectiveness in photovoltaic boards whereas at the same time improving the execution of warm sun based frameworks. It's vital to note that the proficiency of PV boards begins to decay when temperatures surpass 40 degrees Celsius [31]. Table (1.1) and Figure (1.4) show the monthly averages of maximum temperature for Palestinian areas.

Table (1.1). Monthly averages of maximum temperature for Palestinian areas [22].

Area	Jan	Feb	Mar	Apr	May	Jun	Jul	Aug	Sep	Oct	Nov	Dec
Hilly Areas	14	15.3	18.7	23.8	28.1	30.7	32.5	32.5	30.6	27.1	21.3	16
Jordan Valley	18.2	19.2	23.5	28.3	32.7	35	36.3	36.3	35	31.8	24.7	20.3
North Wes Bank	14.8	15.7	18.7	23.3	27.8	30.6	32.5	32.9	31.2	28	22.2	16.8

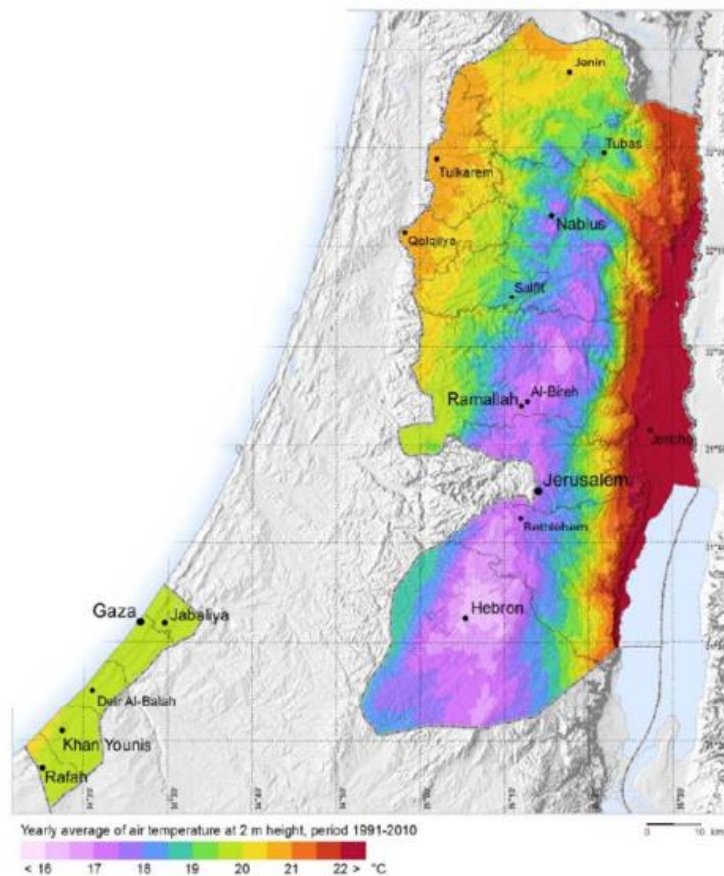

Fig. (1.4). Annual average air temperature at 2 m height, period 1991-2010 [29]

After intensive examination of the given information, able to draw the taking after conclusions: 1.The reality that all normal temperatures stay underneath 40 degrees Celsius proposes that all sun powered vitality frameworks are working effectively. Solar PV boards display ideal execution amid the months of January, February, November, and December. They perform well in April, May, June, September, and October, but their effectiveness diminishes in July and August. It's worth noticing that PV boards still create a critical sum of vitality amid the more smoking months, much obliged to the higher sun powered irradiance within the summer. These perceptions ought to be carefully considered when evaluating the possibility of sun oriented PV plants, particularly when alluding to temperature information for Palestine from PENRA between 1975 and 2005. The information shows that the annually normal temperature remains decently steady all through the seasons, making perfect conditions for the unhindered utilize of solar PV boards. In any case, there's a special case within the Jordan Valley districts, where temperatures can surpass 40 degrees Celsius amid parts of the summer. In such occurrences, it is prudent to take monocrystalline PV boards, as they display way better resilience to tall temperatures [25].

Wind and Relative Humidity Effects:

Palestine, arranged along the Mediterranean coast, encounters shifting levels of mugginess. Gaza, found on the coast, has the most elevated mugginess, whereas Jericho, more distant inland, brags the most reduced stickiness levels. The West Bank, situated around 50 kilometers from the Mediterranean shoreline, is impacted by the heading and quality of the winning winds, which can lead to changes in vapor concentration. Thus, the relative stickiness in numerous locales of Palestine does not acclimate to a settled pattern [14].

The presence of wind and water vapor within the environment has unmistakable impacts on the radiation. Water vapor, for occurrence, assimilates a parcel of the vitality from the approaching irradiance within the infrared range, which is the imperceptible infrared band [32]. Wind in desert-like locales mixes up little tidy and sandy particles, causing them to gotten to be suspended within the environment, shaping what we call "aerosols." The increment in mist concentrates within the sky leads to more prominent scrambling or dissemination of daylight within the unmistakable and bright parts of the radiation range. This marvel is especially recognizable within the Jericho region inside

the Jordan Valley when the south wind blows. Besides, the southern and eastern winds moreover influence the central Palestinian regions. Ranges with rises surpassing 700 meters tend to have the slightest airborne concentration. On the other hand, the western wind that begins from the Mediterranean is moderately clean and is the winning wind in most of Palestine, differentiating with the southern and eastern winds that carry particles from the deserts [22].

Radiation levels regularly connect with the Vaporized Optical Profundity (AOD) esteem, as said in reference [22]. Whereas there's right now no particular information, report, or distribution tending to this figure straightforwardly, long-term meteorological radiation information may in a roundabout way account for this impact. In any case, it's worth noticing that AOD moreover has an extra affect, driving to expand operational and support costs for photovoltaic boards in leave situations or coastal locales [14]. Table (1.2) and figure (1.5) provide the relative humidity and wind data for the major cities [22].

Table (1.2). Relative humidity, evaporation, and rate of wind speed [22].

A- Hebron Site Representing Hilly Areas (Irradiance Level A):

month	Jan	Feb	Mar	Apr	May	Jun	Jul	Aug	Sep	Oct	Nov	Dec
Relative Humidity %	76.5	75.6	71	62.3	59.9	64.3	66.2	68.9	69	67.4	64.4	71.3
Wind Speed Average km/h	13.8	13.6	10.8	13.5	12	11.6	12	11.7	12.1	11.3	11.5	11.6

B- Jericho Site Representing Jordan Valley (Irradiance Level B):

month	Jan	Feb	Mar	Apr	May	Jun	Jul	Aug	Sep	Oct	Nov	Dec
Relative Humidity %	53.9	54	46.8	40.8	38.8	40.3	43.5	45.5	44.1	43.8	45.2	48.9
Wind Speed Average km/h	7.6	5.6	6.5	8.2	8.7	9.1	8.8	9.1	7.5	4.8	4.3	5.1

C- Nablus Site Representing North West Bank (Irradiance Level C):

month	Jan	Feb	Mar	Apr	May	Jun	Jul	Aug	Sep	Oct	Nov	Dec
Relative Humidity %	76.3	76.7	73	65.4	62.3	66	67.8	69.1	67.5	63.5	61.3	69.8
Wind Speed Average km/h	8.2	8.1	8.1	9.5	9.4	10	10.6	10.2	8.9	8.5	7.1	7.1

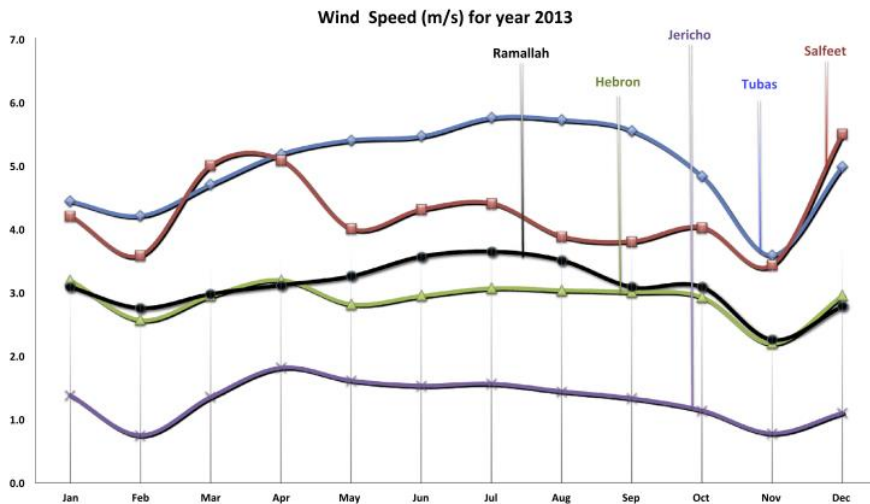

Fig. (1.5). Monthly wind speed in different cities in West Bank in year 2013[29].

Sky Clearance Effect:

Cloud arrangement could be a result of different discuss development forms, and their exchange comes about in critical cloud elements. These clouds play a significant part in constricting sun oriented radiation, which straightforwardly impacts the generation of sun oriented vitality. As a result, control plants cannot reliably create vitality from dawn to nightfall. Evaluating control era in different locales depends on variables such as the sky's clarity and the nearness of clouds. For particular Palestinian areas, meteorological stations have measured the day by day term of clear, cloud-free hours. This data is accessible in Table (1.3) of the 2009 "Climatic Report for Palestinian Areas" issued by the Palestinian Central Bureau of Insights (PCBS) [22].

Table (1.3). Daily shining hours in Palestinian areas [22].

month	Jan	Feb	Mar	Apr	May	Jun	Jul	Aug	Sep	Oct	Nov	Dec
Shining hours (h) in Jordan valley areas	5.8	6.8	8	9.4	11.2	11.9	11.9	10.9	9.8	7.8	7.5	5.7
Shining hours (h) in West Bank middle areas	6	7	8	9.5	11.5	12.3	12.5	12.5	9.9	8.1	7.8	5.3
Shining hours (h) in West Bank South-ern areas	5.4	6.1	8	9.1	11.2	11.4	11.5	11.5	9.2	7.6	7.2	5.5
Annual rate of shining hours at which PV systems work at full capacity (h)												5.7

Table (1.3) gives data on the yearly rates of day by day daylight hours in numerous districts. Within the southern portion of the West Bank, there are around 8.64 h /day, whereas the Jordan Stream region encounters around 8.9 h /day, and the center West Bank regions appreciate almost 9.1 h /day. It's worth noticing that PV (photovoltaic) frameworks in Palestine work at full capacity when there are 5.7 hours of daylight per

day. In Figure (1.6), you'll discover a graphical representation of a clearance file, which is based on the measured daylight hours information and the month to month rate of potential sun based hours calculated on the 15th of each month [22].

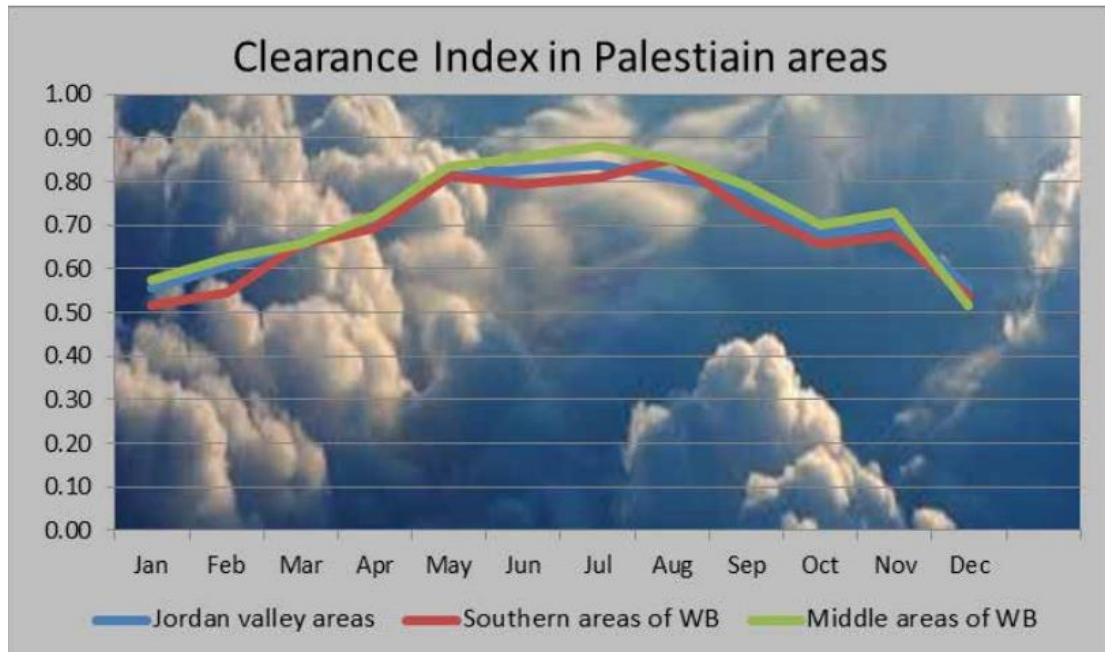

Fig. (1.6). Clearness index % in Palestinian areas [22].

The clarity record portrayed in Figure (1.6) proposes that Palestinian districts regularly appreciate clear skies for the larger part of the year. The clearest skies, with the most noteworthy clearness file values, are watched from May to September, coinciding with the top hours of daylight. This demonstrates that the ideal utilization of sun powered control happens over a five-month period (May to September), with favorable sun powered control generation too conceivable in August, April, and October. On the other hand, there are as it were four months within the year when sun oriented control accessibility is comparatively moo (January, February, November, and December). It's critical to note that this list takes into consideration not as it were cloud cover but too the presence of tall airborne concentrations within the atmosphere[22].

The clearance record can too work as a representation of the change between the anticipated sun powered asset information and the genuine information amid control era. With get to extra meteorological data from the particular area of a photovoltaic (PV) control plant, it gets to be conceivable to improve the exactness of control era investigation. Figure 16 outlines negligible deviation amid the summer season, which implies a more reliable control era handle. This observation further approves prior

discoveries related to overseeing vitality request amid winter conditions and the benefits of grid-connected PV control systems.

Solar Energy Potential Map:

The major cities and populated locales in Palestine are well-connected through a arrange of streets that's very thick. Having great openness is fundamental for the successful foundation of an vitality arrange centered around saddling sun based vitality assets. When considering the geological variables, it is suggested that photovoltaic (PV) establishments are in a perfect world arranged on tenderly slanting landscape confronting south, in ranges with negligible characteristic sources of contamination, such as sandy or undeveloped arrive. These favorable conditions can be found in both the eastern and western regions of the West Bank, as well as within the eastern portion of the Gaza Strip[22].

For the perfect placement of PV frameworks, it is suggested to choose ranges with direct wind conditions or prefer areas such as sloping territory, where wind can improve the system's execution. In locales just like the western portion of the West Bank, the nearness of winds can give a cooling advantage to PV modules. On the opposite, ranges just like the Gaza Strip, with higher wind speeds, and the eastern districts of the West Bank, where winds may carry clean or pollution from urban, leave, and agrarian zones, are less favorable. Typically since in these districts, solid winds can lead to expanded collection of soil on the surface of PV modules, lessening their proficiency and raising operation and support costs [22].

In Figure (1.7) the yearly PV power yield per kilowatt-peak (kWp) of a standard open-space PV framework. This information is displayed in kilowatt-hours per kilowatt-peak (kWh/kWp). Calculating the PV yield for 1 kWp of introduced control permits us to extrapolate the anticipated control generation for PV frameworks of changing sizes. It's worth noticing that the power era is essentially impacted by the geographic area of the control plant [22].

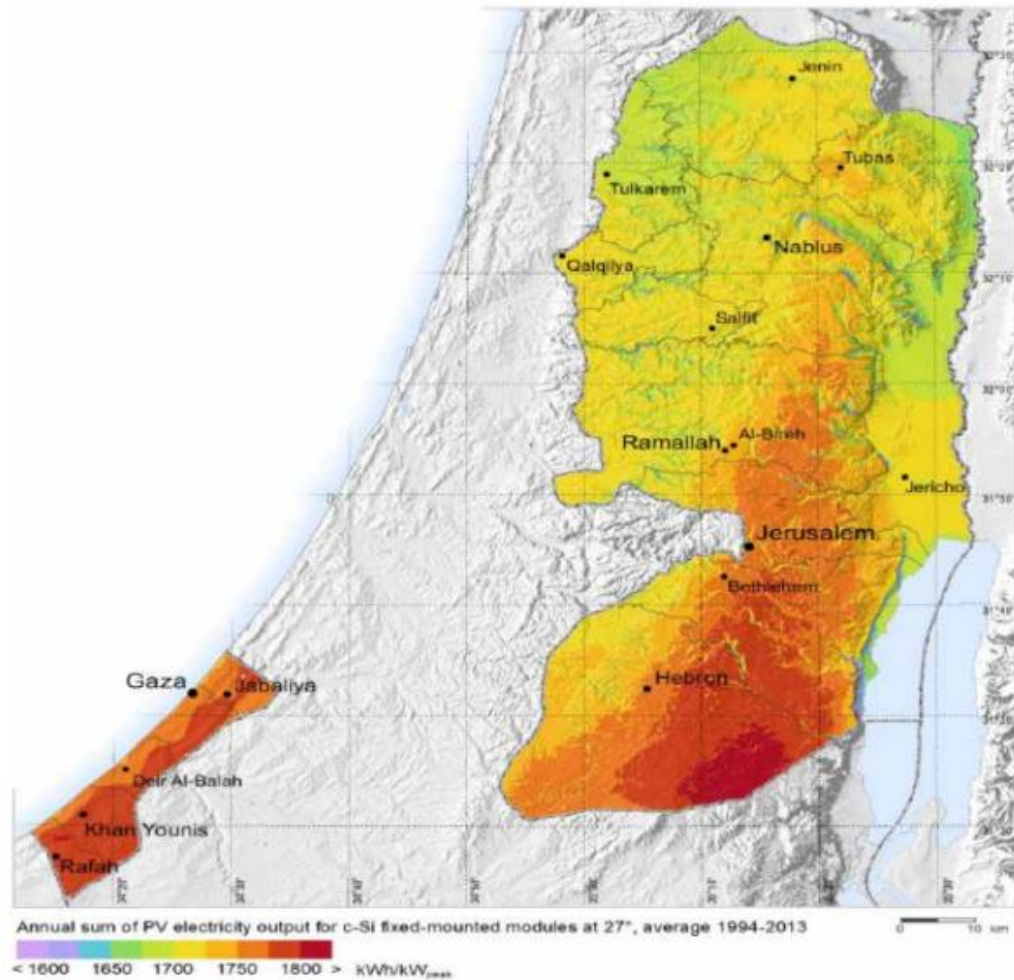

Fig. (1.7). Annual PV electricity output from an open space tilted due south with 270 with a nominal peak of 1 kW [23].

Table (1.4) outlines the expected electrical yield and execution effectiveness of photovoltaic (PV) control offices, taking into consideration the winning climatic conditions in unmistakable districts with shifting levels of sun based light. In Palestine, the particular PV control era values from a standard reference framework, as point by point within the table, extend between 1700 and 1765 kWh/kWp for the three chosen ranges. Outstandingly, the potential vitality abdicate in Gaza and the southernmost portion of the West Bank surpasses 1800 kWh/kWp, speaking to the most noteworthy achievable values in those locations [22].

Table (1.4). Annual average of electricity yield of 1 kW PV panel tilted due south with 270 [23].

Palestinian Areas with Different Irradiance Levels			
	level A	level B	level C
PV Electricity yield for fixed-mounted modules at optimum angle "kWh/kWp"	1765	1715	1703
Optimum Angle "Degree"	27	27	27

Whereas the chosen locales in Palestine encounter distinctive climatic conditions due to their different topographical zones, the power generation in photovoltaic (PV) control plants remains to a great extent reliable and basically depends on sun based illumination. Control generation mapping demonstrates that amid the summer months, the control yield in Palestinian locales shows a limit extend of varieties on a month to month premise. Thus, the summer season from May to Admirable offers the potential for achieving tall and relentless power production [22].

In terms of climate-related components, it's worth noticing that the Gaza location in Palestine encounters the most elevated photovoltaic (PV) electrical generation, whereas the Jericho location has the most reduced, creating around 1703 kWh per kilowatt crest (kWp). The uniqueness of the Jericho location lies in its position inside the Jordan Crack Valley, where raised discuss temperatures contribute to a decrease in power era .By the by, it's imperative to highlight that actualizing following frameworks can improve the vitality yield of PV control plants by as much as 40%.

Conversely, sun based warm frameworks show a better resistance to temperature varieties and the nearness of mist concentrates when compared to photovoltaic (PV) boards. This flexibility can be credited to the broader run of sun based radiation frequencies tackled by sun powered warming boards, as contradicted to PV boards that basically utilize high-frequency sun oriented radiation. Sun powered water warming frameworks have the potential to see developing selection in private, commercial, and mechanical settings. Leveraging the extensive existing foundation and broad encounter in this field, contributing in sun powered water radiators gets to be a more cost-effective and possibly beneficial alternative, advertising moderately brief payback periods [33].

1.3 Background

The West Bank and Gaza Strip, commonly known as the Palestinian Territories (PT), are located at a geographical latitude of approximately 30 degrees solar latitude, with annual solar radiation of approximately 2,000 kilowatt hours/m². However, they are not

like that have resources about natural energy; All of the country's electricity and fuel is imported from Israel, where it is obtained from imported coal and oil, in addition to electricity imports from Jordan and Egypt. Currently, PT's peak load is about 650 MW, with an average per capita of about 200 W; but this value has increased in recent years as the demand for electricity has increased in all areas of life. Electricity in Palestine accounts for 31% of total energy consumption according to the Central Statistics Office's energy balance in 2018. The interior of Palestine is the largest consumer of this energy with 60%, followed by the service and commercial sector with 26%, and the industrial sector consumes 13%; the agricultural sector consumes less than 1%. Palestine is characterized by strong growth in electricity demand; this amounts to about 7% per year despite high imported energy prices. Therefore, it is not surprising that in such a situation, Palestine shows great interest in using solar energy as an alternative energy source.

In addition to the growing demand for electricity in the PA areas, there are also C areas that are not under philosophical jurisdiction and where people need electricity and under full Israeli control in these areas, the Using energy scent diffusers of these areas helps provide the necessary electricity to the residents in these areas.

There are more than 3,000 schools in Palestine (West Bank and Gaza Strip) that require electricity during the year and in varying proportions, as these schools have approximately 180 days during the school year. which means that the use of solar panels on the roofs of these schools produces the energy you need and the surplus of power is pumped through the electrical grid, In previous years, the Ministry of Education had worked to implement a number of streets on the roofs of schools, making the study of solar energy projects and their dissemination to schools an idea that needed attention and follow-up The study involved the planning and implementation of three rooftop projects in the Beit Fajjar area of southern Bethlehem.

1.4 Literature review

The building sector is the highest energy consumption sector in the world, and because of the significant increase in energy demand and use in buildings, the authorities and influential authorities in all countries have turned to a policy guiding the use of energy in buildings in addition to increasing the efficiency of the use of these buildings in the

provision of energy and making them an energy source and not only a source of energy consumption [34].

The researchers studied solar energy systems on the roofs of schools in Palestine, and as a special case, the study of Alsamamra and Shoqier, 2021, the authors choose al-Dhaheriya High School located in the city of Dhaheriya - south of the West Bank, one of the schools of the Directorate of Education / South Hebron, this school was chosen for its middle area, which has an area of 670 square meters, and also because of its presence in the city of Dhaheriya with a semi-desert climate, this study was worked through the collection of data on the school in terms of area and consumption monthly energy, then use the H simulation program to calculate the ratios of solar radiation and the amount of energy generated in this area, Finally calculating the cost of the project and consumption as well as calculating the recovery period, 490 square meters of surface was used, in this solar system the resulting is 57.16 KW, using 144 solar panels, this system produces 92866 KW, and consumes school 4 237 KW, this means that the surplus of energy is 88,626 KW and can be sold from energy by 14,181 USD, the project cost is estimated at 65,000 USD, the recovery period for the project is 4.38 years, and the total income After 20 years it reaches 283,620 USD, and at the end of the study the researchers call for the generalization of this work and strengthen the use of solar systems in all schools of Palestine of 3074 schools [35].

Ajlouni and Alsamamra, 2019 presented the Review of Solar Energy Prospects in Palestine to find out the situation and conditions of the exploitation and use of solar energy in Palestine, in Palestine a complex system of energy different from all countries in the region due to the existence of obstacles to the existence of an easy energy system in Palestine and the Israeli occupation is the most obvious of these obstacles, the aim of this work is to provide a comprehensive review of the prospects of solar energy in Palestine in many respects such as its geographical data and its legislative and economic possibilities, the researchers based In this study to provide information analysed about the characteristics of solar energy in Palestine in terms of geographical location and legislative and economic policies the research concluded the strengths and disadvantages of the use of solar energy in Palestine, as well as recommendations, One of the strengths that promote the use of solar energy in Palestine is Palestine receiving 3,000 hours of solar radiation per year, and the average values of solar radiation in Palestine range from 5.4 kWh/m² day to 6.0 kWh/m², the lack of Israeli barriers to the import and generation of solar energy, the high prices of electric power and fuel, which

enhances the use of solar energy in Palestine, the presence and availability of engineers and technicians working in the field of solar energy, the presence and support of government to establish Solar projects in various regions and sectors, the presence of some foreign partners in the implementation of solar projects in Palestine such as the European Union and the Japanese government, as well as the cooperation of electricity companies in promoting the use of solar energy and other strengths for the use of solar energy in Palestine, On the other hand, the study presented the weaknesses and disadvantages of the use of solar energy in Palestine, including these defects, the repeated Israeli aggression on the Areas of the West Bank and Gaza and the bombing of buildings and installations as well as the division of the West Bank into areas A, B, and C, which hinders the exploitation of areas in areas C, the lack of consolidation of efforts and studies in the field of solar energy, which leads to poor research on this subject, the lack of a mod source and reliable energy data Solar in Palestine, the lack of laws controlling construction to observe the use of solar energy, and the weak infrastructure of Palestinian electricity companies, In any case, the researchers made a set of recommendations at the end of the study which can be summarized in the following, verification of solar radiation data, strengthening research and studies in the field of solar energy and unifying efforts to produce effective and effective results, issuing laws by the authorities that support and promote the use of solar energy in Palestine, as well as the establishment of a national center of solar energy in Palestine, in the end the researchers confirmed that the best areas for solar projects in Palestine is the south of the West Bank The west and Gaza, and the worst area for solar projects in Palestine is Jericho [14].

Ibrik, 2020 studied the technological-economic assessment of solar energy projects in Palestine, by tracking the productivity of the solar system on the roof of the Faculty of Medicine at The National University of Success - Palestine by tracking the productivity of the system for three years 2016, 2017, and 201 8, the average total electricity produced and pushed into the grid was 66,571.5 KWh per year and a total profit of USD 11,982, the researcher added the importance of this study and the information provided by the study in providing information on energy systems Solar in Palestine and its importance, and provide important information to policymakers and individuals about the feasibility of installing solar systems associated with the grid in Palestine [36].

Ibrik and Fadia, 2019 studied the evaluation of solar systems on the roofs of schools in Palestine, in this study was selected three schools to apply a solar system on the roof of each of these three schools: Al-Razi Boys School, Almueh Boys School and Khawleh Bent Al Azwar Girls, the goal is to apply a solar system with the capacity of 7.68 kWp and an area of 40 square meters on the roof of each of these three schools, the average production of each of these three systems 10.930 MWh/year encourages intensified efforts in the dissemination of solar systems to all schools of Palestine Because of its productivity, where the price of a kilowatt hour is estimated at about 0.1 USD, in addition to this method in producing energy clean, safe and environmentally friendly, and it turns out that the recovery period for these projects is less than 5 years, and the researchers recommended to the Palestinian Ministry of Education to move towards the design of solar systems on all schools in Palestine because of the benefit to schools and the productivity of electricity pumped into the network connected to solar systems on the roofs of schools [37].

Wentao and Slameh, 2014 presented a study that included the design of an PV system for Off-Grid Photovoltaic System, the solar system produces energy of 14,712 kWh and at a total cost of 41,735 USD, the independent system facilitated the difficulties of systems connected to the network and the researchers explained that it has prospects Large, through the simulation program pvsyst the project will produce an amount of energy during its first year, and the total capacity during 25 years of the project will be about 334,563.4 kWh, the researchers calculated the recovery period for the project which amounted to 10.71 years, Compared to the recovery period in developing countries of 6.76 years [38].

1.5 Statement of the problem

The main objective of this work is to study the insurance of energy needs through school roofs, and to study the feasibility of these projects in securing energy needs by conducting the study on three schools in Beit Fajar- Bethlehem.

The main objectives of the present study are to:

1. To study availability of solar energy in Three schools in Beit Fajar - Bethlehem.
2. To investigate practical applications of solar energy in its thermal and electrical forms.
3. Solar Environmental and Economic Impact Statement.
4. To plan for solar energy share as an energy source.

5. Propose new ways to produce energy and eliminate traditional energy sources such as fossil fuels.
6. To recommend new legislations and administrative rules to encourage people for depending more on solar energy.
7. The importance of using and applying solar energy systems on all rooftops of schools in Palestine by the Ministry of Education.

1.6 Justification

The world is moving fast in the field of renewable energy and its use in various areas of life [39][40].

The repercussions of the use of fossil fuels on humans and nature and the damage caused by its use, as well as the shrinking supply of fossil fuels as a result of economic and political reasons. [41][42].

The three schools were selected: Male Liberation Basic School, Beit Fajar Girls High School, and The Rock Basic School in Beit Fajar for the following reasons:

The three schools have different schools in the area as the area of the male primary liberation school is about 394 m², the basic rock school 616 m², and the girls' school Beit Fajar high school 780 m², which contributes to the comprehensiveness of the study on different areas and the possibility of spreading this to different schools in the area.

The presence of the three schools in the Area of Beit Fajar, which is considered to have high consumption of electricity as a result of the population and the presence of stone cutting factories in large numbers.

The presence of solar energy projects on part of these schools in different areas, enabling us to compare the productivity of the current energy project with new renewable energy projects.

Chapter Two

Theoretical Frame Work

2.1 PV systems

In this section, the components and types of the PV systems will be clearly discussed.

2.1.1 Types of PV system

Photovoltaic systems are classified based on their performance and performance requirements, the structure of the components, and the connection of the equipment to other power sources and power loads. There are two main classifications of PV systems: the first is a stand-alone or off-grid system and the second is a grid-connected or grid-connected system.

Off-Grid system configuration

Off-grid solar systems, or off-grid systems, are designed to operate independently of the power grid to deliver DC and/or AC electrical loads to rural areas off the power grid. Battery storage and synthesis are used to provide constant power, but batteries are expensive and reduce system efficiency.

The charge controller limits the rate of current that is sent to the battery bank and protects the batteries. Great price Figure (2.1) shows the current flowing from the PV array through the charge converter and battery bank before being converted to AC by the off-grid inverter. Off-grid converters, unlike grid-connected converters, do not need to be in phase with the utility waveform [43].

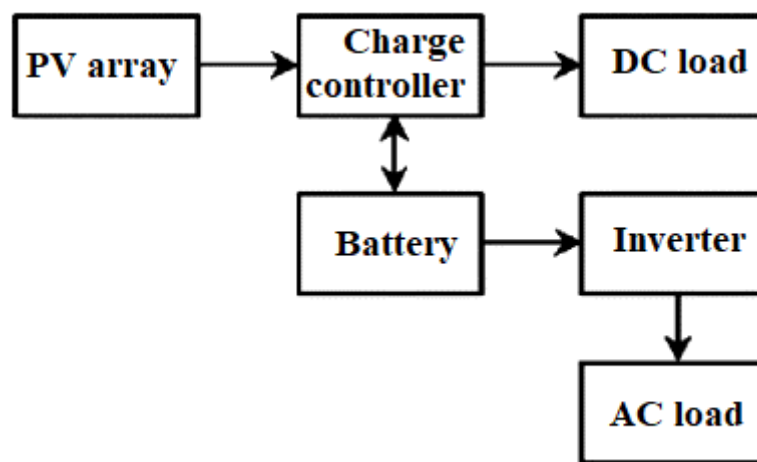

Fig. (2.1). Configuration for standalone system

On grid system configuration

Photovoltaic systems are designed to operate connected to the electrical grid. The main component of a grid-connected PV system is the grid-connected inverter (GTI). A dual interface is usually established in the switchboard between the output circuit of the PV system and the power grid. This allows the AC power generated by the PV system to supply electrical loads on site or to be fed into the grid when the output of the PV system exceeds the load demand. At night and other times when the electrical load exceeds the output of the PV system, the remaining power required for charging is produced from the electrical equipment. As shown in Figure (2. 2), the DC-DC converter steps up the step voltage to a higher level, and the GTI converts the DC power generated by the PV array into AC power to meet the requirements of the distribution network, and then automatically cut off delivery It provides power to the grid when the utility grid is not powered [44].

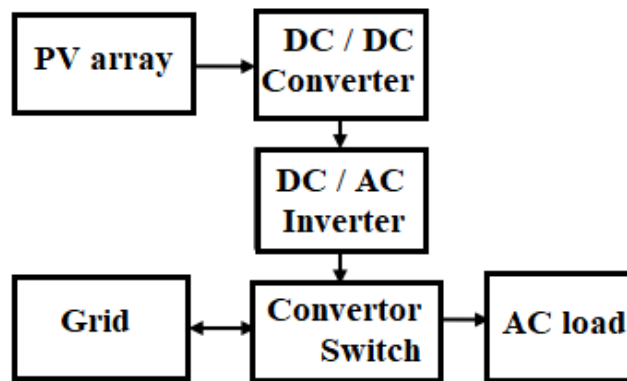

Fig. (2.2): Configuration of grid tied system

Hybrid system configurations

Hybrid solar systems combine the advantages of stand-alone and grid-connected photovoltaic systems. These systems can be pure solar with utility backup power or grid-connected solar with backup battery storage, as shown in Figure (2.3).

Hybrid solar systems are cheaper than conventional solar systems because the capacity of the battery bank can be reduced. In this system, excess electricity from solar panels can be temporarily stored in batteries and then sent to the grid. Hybrid solar systems use grid-connected inverters connected to a battery. These devices can obtain power from battery banks and synchronize with the power grid [44].

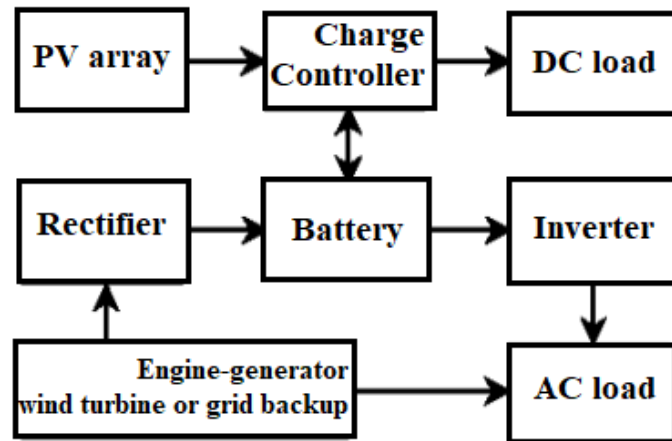

Fig. (2.3): Configuration of hybrid solar system

2.1.2 Comparison between on-grid and off grid PV systems

Advantages and Disadvantages of On-Grid and Off-Grid Solar Systems [43]:

Advantages of off-grid systems

- In most emergency situations, you will have access to electricity.
- No electricity bills.
- The best choice for remote locations where connection to the power grid is expensive.

Disadvantages of off-grid systems

- You should carefully plan your energy consumption.
- Adding batteries to the system may cause some malfunctions. Batteries consume energy during charging and discharging, reducing the efficiency and output of a solar system, increasing costs and installation costs, and increasing system complexity. Also, the battery has to be replaced and it is expensive before replacing other parts of the system.
- Stand-alone systems often include additional generators, which are expensive and require maintenance.

Advantages of the grid system:

- No need for expensive batteries and generators, reducing maintenance costs. Therefore, it is cheaper and easier to install.
- The electrical operation is similar to that of the battery, which requires no maintenance or replacement, which is better. This means more energy is wasted using traditional battery systems.

- Other benefits of grid connection include access to backup power from the utility grid if the solar system stops producing electricity for any reason. At the same time, it is a grid-connected system that reduces the peak load of the power company. As a result, your electrical system will be more efficient.
- Electricity bills are reduced as efficient ones can sell electricity to the grid at a higher price and get it back at a lower price at night. Grid connection allows consumers to save more money with solar panels through net metering.
- The annual average electricity supply and distribution is around 7% of the electricity supplied. On the other hand, lead-acid batteries commonly used with solar panels only have a storage capacity of 80-90° and degrade over time.
- Simple system. Users stay connected to the local grid, regardless of bad weather, and can draw power from the grid when solar power production drops or is interrupted.

Disadvantages of network systems:

- Damage from photovoltaic solar systems to the electrical grid (signal quality).
- In the absence of solar energy, users continue to use non-renewable resources.
- The cost of extending the transmission lines to the network.
- If the power supply runs out, the solar power facility will also shut down due to lack of battery storage, causing users to experience power outages.

2.1.3 Components of on grid system

1. Photovoltaic modules:

Solar PV systems are powered by many thin or thin film PV modules. Individual photovoltaic cells are connected to form a photovoltaic unit. The PV modules are then connected to the PV strings and a PV array is formed by connecting the PV strings in parallel to achieve the required voltage and current. Photovoltaic cells are made of photosensitive semiconductor materials that use photons to absorb electrons to drive an electric current. There are two main types of technologies used in PV: The cells that make up the majority of photovoltaic cell production are sandblasted; and newer and increasingly popular fine films. The most obvious difference between PV cell technologies lies in the conversion efficiency, which is summarized in Table (2.1) [45].

Table (2. 1): Conversion efficiencies of various PV module technologies.

Technology	Module Efficiency
Mono-crystalline Silicon	12.5 – 15 %
Poly – crystalline Silicon	11 – 14 %
Copper Indium Gallium Seleide (CIGS)	10 – 13 %
Cadmium Telluride (CdTe)	9 – 12 %
Amorphous Silicon (a- Si)	5 – 7 %

After selecting the module type, the next step is to decide how many modules you need and how to connect them. The number of units is determined by the size of the system in the network, because the system does not provide 100% of the energy requirements. In a real system, the number of components depends on the load requirements. The peak power (W_p) of the PV generator is obtained from equation (2.1).

$$P_{PV} = \frac{E_L}{\eta_V \eta_R PSH} S_f \quad (2.1)$$

Where:

E_L : Energy consumption per day .

η_V : Inverter efficiency.

η_R : Charge controller efficiency (in standalone system).

PSH: the peak sun hours.

S_f : the safety factor (in grid tied it not necessary to put safety factor) .

P_{MPP} : represent the maximum power point power.

The number of necessary PV modules is obtained as:

$$NO_{.PV} = \frac{P_{PV}}{P_{mpp}} \quad (2.2)$$

The number of components in series (NS) is determined by dividing the system voltage V by the system (usually determined by the battery bank or inverter). Voltage V rated voltage under standard test conditions (STC).

$$N_S = \frac{V_{System}}{V_{Module}} \quad (2.3)$$

The quantity of strings can be determined by dividing the total number of modules by the number of modules in series.

2. Charge Controller:

A charge controller is required on real systems (with battery backup). The main function of the charge controller is to prevent the battery from overcharging and

discharging. The charge controller prevents charging back to the PV modules at night. Some of the new charge controllers include a high voltage signal monitoring unit that optimizes the output of the PV array to maximize the output power [4]. The hiring manager is chosen based on: reasons:

- PV array voltage: The input voltage of the charge controller must be equal to the nominal voltage of the PV array.
- PV cell current: The charge controller must be sized to handle the maximum current generated by the PV cell multiplied by 1.25.

3. inverters:

Inverters used in PV systems convert DC power from PV modules or battery banks into AC power, ensuring that the AC conversion frequency is 50Hz, THD < 3%, reducing voltage swings and ripples. AC is pure waves for grid connected systems.

For network-connected conversions, please note the following:

- Direct current voltage generated by the photovoltaic array or the battery bank.
- DC power from photovoltaic arrays
- Inverter quality such as high efficiency, good frequency and voltage regulation.
- MPPT (maximum power point tracking) function.

The inverter DC voltage input must match the nominal PV array voltage for batteryless systems and the inverter input must match the battery block voltage for standalone systems. The size of the grid connected inverter is determined by the power output of the PV array, not the load requirements of the house. The nominal power of the external inverter is selected according to the maximum load ($P_n=1.2 \cdot P_{\max, \text{load}}$).

The output of the inverter must meet the following requirements of the municipal electrical network: 220V; Sinusoidal voltage of 50 Hz. Modern inverters are 92-94 efficient, but inverters for real systems are less efficient. Grid connected converters include monitoring of high voltage points. MPPT automatically adjusts the system voltage so that the PV array operates at its maximum output. For real systems, this feature is included in paid drivers [46].

3.Cables:

A sun powered cable intercontinental sun oriented boards and other electrical components of a photovoltaic framework. Sun powered cables are outlined to be UV safe and climate safe. It can be utilized inside a huge temperature run. The PV generator comprise of person modules associated by sun oriented cables. The module cables are

associated into a string which leads into the generator intersection box, and a primary DC cable interfaces the generator intersection box to the inverter. The positive and negative cables are laid independently in arrange to dispose of the chance of ground flaws and brief circuits. Legitimate wire measuring depends on the current that will be carried by the wire, to decide wire sizes for the cluster, it is essential to recognize that beneath certain bizarre conditions, it is conceivable for the reflection from cloud to center the daylight on an cluster. This marvel requires that the wire be able to carry the cluster current as improved by cloud centering. To allow for cloud centering the cluster brief circuit current is increased by 1.25 to get the most extreme current from cluster to controller. This most extreme cluster current is at that point increase by another figure of 1.25 as required for persistent prerequisite, and wire sizes are at that point chosen to meet this ampacity necessities. The wiring of PV circuits must hence be able of carrying 156% of the brief circuit current [47].

2.2 Methodology

In this section we will provide climate properties of the study area and the working phases in order to obtain the results.

2.2.1 Study area

The geographical boundaries of Palestine are defined by its location between 34.15° and 35.40° east longitude and 29.30° and 33.15° north latitude. The map of Palestine vividly illustrates its diverse topography and climatic conditions. Covering a total area of 27,000 square kilometers, Palestine is bordered by Jordan and Syria to the east and Lebanon to the north. Palestine holds immense religious significance for Muslims, Christians, and Jews alike. Its strategic geographical location facilitates robust trade connections with neighboring regions. Positioned along the Mediterranean Sea, Palestine boasts a natural harbor that effortlessly links three continents: Europe, Asia, and Africa.

The site played a key role in shaping the Palestinian climate in terms of the impact of the eastern coast of the Mediterranean Sea, the Sinai Desert and the Jordanian Sahara. This makes it subject to marine and desert influences in addition to being exposed to solar radiation. Palestine's terrain played an important role in shaping these features. Palestine is characterized by the diversity of its climatic territories despite its small area, which belongs to the moderate Mediterranean region, and has a tropical, desert and

semi-Saharan climate. The Mediterranean Sea has had a significant impact on the diversity of its climate, which is influenced by western winds accompanying air depressions, especially in the northern regions of Palestine. Palestine's climate is moderate compared to the Middle East, but there is a clear difference in Palestine's climate between southern and northern Palestine and between coastal plains and marshlands. As a result of Palestine being located far from the areas of concentration of the air depressions around the island of Cyprus, the Negev desert, where rainfall decreases to about 50 mm per year, and areas in the rain on the eastern slopes and the territory of the demolition pit are low-rainfall desert areas, and other climate elements vary from region to region as a result of multiple factors.



Fig. (2.4): Map of West Bank and Gaza

2.2.2 Beit Fajjar location

The location of the study is the city of Beit Fajjar which is located in the center of Palestine, the town of Beit Fajar is a town in Bethlehem governorate, located south of Bethlehem city, 10.3 km of which is bordered from the east by the village of Al-Maniyah, from the north by the villages of Marah Rabah and Umm Salmouna, from the west by the settlement of Kfar Etzion, and from the south by the town of Sayir and the village of Sheikh al-aroub al-aroub.

The town of Beit Fajjar is located at an altitude of 929 meters above sea level, with an annual rainfall rate of about 621 mm, while the temperature rate is Faisal to 16 ° C, and the relative humidity rate is about 61%. (Geographic Information Unit – Areg, 2009).

Bayt Fajjar is considered the Mountainous area, the overall maximum temperature during the year is 19 degrees Celsius, The overall minimum temperature rate is 11 ° C, while the overall temperature rate is 15.5 ° C, The overall rate of relative humidity was 61.75%, and the overall rate of atmospheric pressure was 901 mB. The rate of sunshine hours during the year is 7.8 hours. The highest brightness of the sun during August was 10.9 hours. The sun's brightness during the months of December and December II was less than 4.7 hours, the overall wind speed rate was 5 km/h and the overall rainfall rate was 621 mm. (Palestinian Meteorological Department 2018).

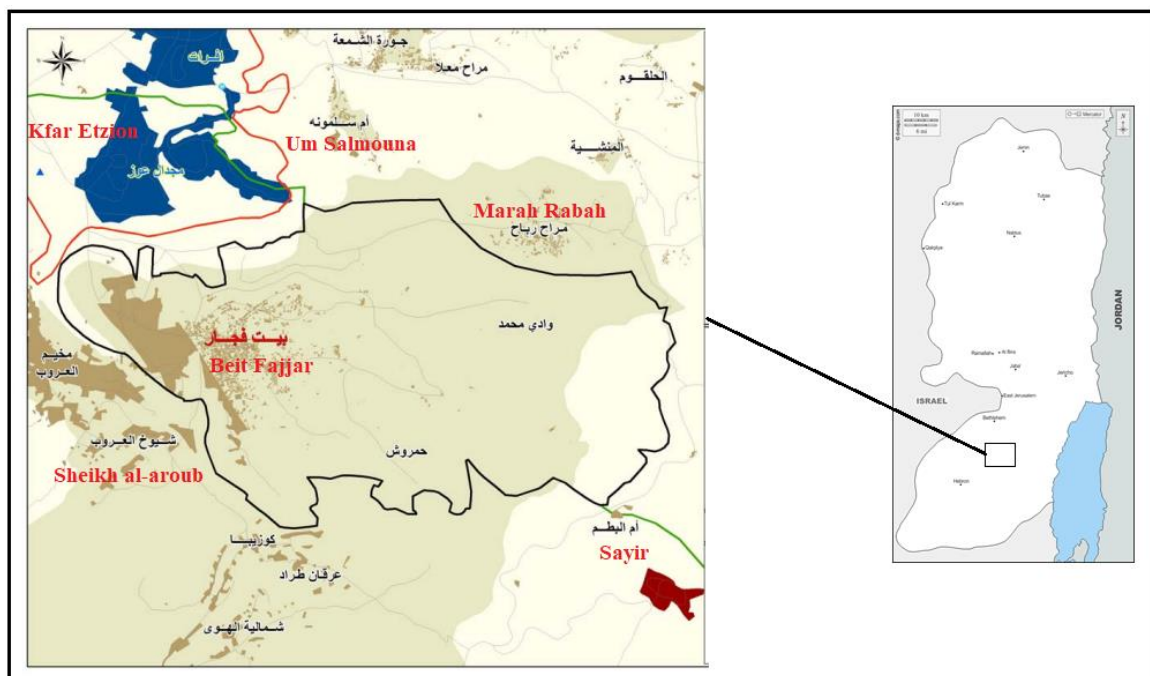

Fig. (2.5): Map of Beit Fajjar.

2.2.3 The selected schools data

With regard to basic and secondary education institutions in the town of Beit Fajar in the current school year 2023/2024, the town has eight schools, three male schools, three female schools and two mixed schools, administered by the Palestinian Ministry of Education. As in table (2.1).

Table (2.2) Distribution of schools in Beit Fajjar by school type and supervisor in the academic year 2023/2024.

school	school supervisor	school type
Beit Fajjar Secondary Boys school	governmental	Male
Al-tahrer primary school		
Al-whda primary school		
Beit Fajjar Secondary girls school	governmental	Females
Al-wafa primary school		
Hefa primary school		
Al-fajer primary school	governmental	Mixed
Al-sakra primary school		

Source: Directorate of Education, Bethlehem (2023).

Three schools will be selected as a case study, namely:

1. Al-Tahrir Boys School :

Table (2.3) School information: Al-Tahrir Boys School

Location	31.62023148899763, 35.15459634733016
Rise from Sea Level	946 m
Number of floors	4
Holdings' total area	394 m²

Source: Directorate of Education, Bethlehem (2023).



Fig. (2.6): Al-Tahrir Boys School

2. Beit Fajjar Secondary Girls School

Table (2.4) School information: Beit Fajjar Secondary Girls School.

Location	31.6222713211251 35.148424098082764
Rise from Sea Level	913 m
Number of floors	4
Holdings' total area	780 m²

Source: Directorate of Education, Bethlehem (2023).



Fig. (2.7): Beit Fajjar Secondary Girls School.

3. Al-sakra primary school

Table (2.5) School information: Al-sakra primary school.

Location	31.628844363115327 35.16147014132889
Rise from Sea Level	920 m
Number of floors	4
Holdings' total area	616 m²

Source: Directorate of Education, Bethlehem (2023).



Fig. (2.8): Al-sakra primary school

2.2.4 Working phases and computer tools

In order to achieve the results we will follow the following phases:

(1) Obtaining the data for the Beit Fajjar region for the study, were Tahrir Boys School , Beit Fajjar Secondary Girls School , and al sakra school was taken to be the case study in this project.

(2) Applying the data of the school to (pvsyst) software , and (PVCAD) software to calculate the amount of the PV system needed and to calculate the power output.

(3) At the end, the total cost of implementing the project for school will be calculated, and then the expected time to recover the cost of the project before starting to sell the energy to the electricity distribution companies in Palestine.

The following computerized programs will be used to find the PV system analysis:

1. PVsyst software

This software used to calculate the amount of the PV system needed and to calculate the power output.

2. PV CAD software

Calculate the amount of the PV system needed and to calculate the power output and represent solar panels on school roofs.

3. Excel Program

Write the spread sheets represented by the output of electricity as well as the intensity of solar radiation, the amount of energy consumed, and the representation of different graphs.

Chapter Three

Results and Discussion

3.1 Introduction

The focus of this study is based on the principle of exploiting the rooftops of buildings in Palestine to generate solar energy by exploiting the rooftops of buildings to establish solar energy projects on them, as there are many challenges facing the energy and electricity sector in Palestine, whether from high electricity prices resulting from high prices. Global fuel, as well as the practices practiced by Israel, which limit in one way or another the availability of electrical energy, in addition to the availability of many roofs that are not used or benefited from, so this study aimed to demonstrate the benefit of exploiting the roofs of buildings in establishing solar energy projects.

As a case study, the exploitation of the roofs of three public schools in Beit Fajjar in the south of Bethlehem Governorate was studied in studying the efficiency of solar systems to generate electrical energy on the roofs of buildings. The schools were chosen for several reasons, the most important of which is the presence of more than 3,000 schools in the West Bank and Gaza Strip, and most of the school roofs are empty. It is not exploited, and schools' electricity consumption is considered low, given that schools are closed for approximately 180 days a year.

This study focuses on the efficiency and productivity of these three systems. In this study, the three schools' electricity consumption was tracked throughout the year according to the official data of the Jerusalem Governorate Electricity Company, and the largest possible area was exploited to implement a solar energy project through the PVsyst software, and all Considerations surrounding the study included the location of the schools and the nature of the components of the solar system. After that, the monthly consumption of the schools was compared to the project productivity, and the project's payback period and economic costs and revenues were calculated.

3.2 PV systems and revenues

In this section, planning and construction of projects using the PVsyst software will be discussed, comparing the results with the monthly consumption of schools, and calculating the payback period for the projects as well as their revenues.

3.2.1 Al-Tahrir Boys School Result.

A) Technical and engineering information and electricity consumption for the Al-Tahrir Boys School.

Technical and engineering information and electricity consumption for the Al-Tahrir Boys School in Table 3.1 were obtained with the assistance of the Ministry of Education - Bethlehem and the Electricity Company.

Table 3.1: Al-Tahrir Boys School building specifications :

Type of building	Males school students
Owner of building	The Ministry of Education
Location	Palestine - Bethlehem - Beit Fajjar
Number of floors	4 floors
The monthly bill ranges	85 -2138 NIS
The surface area of the school	394 m ²

B) Electricity consumption.

Table (3.2) and "Fig.(3.1)" shows the school annual electricity consumption and its financial cost. We need this information and use it to calculate the capacity of the system needed to cover the school's needs and financial cost.

Table 3.2: Electricity consumption and financial cost (kWh and NIS) for Al-Tahrir Boys School.

Month	Meter reading	The consumption value (kwh)	The bill value (NIS)
Jan-19	1684	908	671
Feb-19	1679	2771	2138
Mar-19	1717	2405	1846
Apr-19	1680	1613	1090
May-19	1727	534	157
Jun-19	1654	113	79
Jul-19	1617	83	58
Aug-19	1523	121	85
Sep-19	1637	1033	723
Oct-19	1851	1053	503
Nov-19	1333	1127	776
Dec-19	1685	1080	648
Annual total		12841	8774

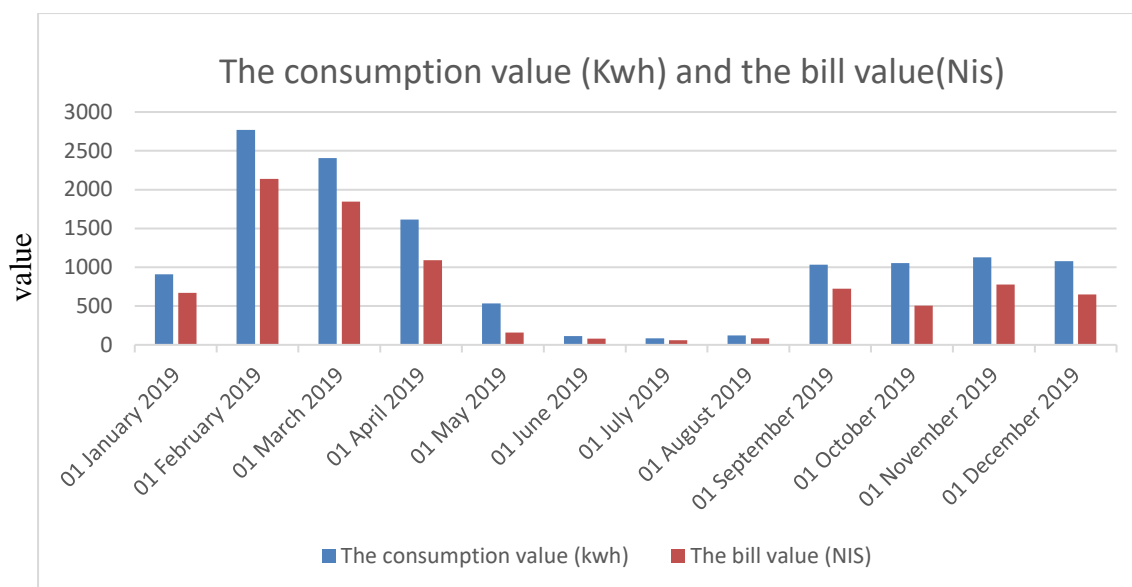

Fig.(3.1) : Electricity consumption and financial cost (kWh and NIS) for Al-Tahrir Boys School .

C) Distribution of the Ret screen in Palestine

Monthly global solar insolation and daily average bright sunshine hours in Bethlehem- Beit Fajjar are presented in table (3.3). These values are an average of solar insolation from an expert Ret screen program. By using the Ret Screen program, the average solar radiation in Beit Fajjar = 5.93 kwh/ m².day.

Table 3.3: Monthly global solar insolation at Bethlehem-Beit Fajjar.

Month	Solar insolation (KWh/m ² .day)
January	3.37
February	4.20
March	5.30
April	6.81
May	7.88
June	8.57
July	8.40
August	7.85
September	6.73
October	5.28
November	3.74
December	3.05
Total /year	71.13
Average insolation	5.93

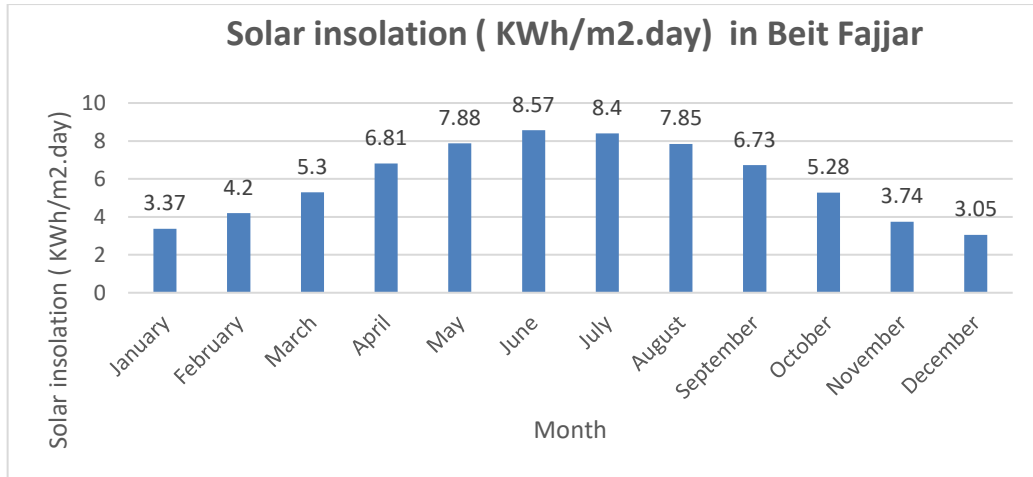

Fig.(3.2) : Solar insolation (KWh/m².day) in Beit Fajjar

D) The size of solar power system.

Based on the school’s monthly consumption quantity, it is necessary to calculate the amount of the photovoltaic system that must be sufficient to meet the school’s need for electrical energy. To know this, we must do the following calculations within the monthly consumption quantity and the specifications of the system that will be designed.

Calculate Average monthly consumption:

$$\text{Average monthly consumption} = \frac{\text{Total consumption at annual (Kwh)}}{12 \text{ month}}$$

$$\text{Average monthly consumption} = \frac{12841}{12}$$

$$\text{Average monthly consumption} = 1070 \text{ Kwh / month}$$

Calculate Average daily consumption:

$$\text{Average daily consumption} = \frac{\text{Average monthly consumption}}{\text{days}}$$

$$\text{Average daily consumption} = \frac{1070}{30}$$

$$\text{Average daily consumption} = 35.67 \text{ Kwh / day}$$

But the losses can reach up to (1.3) due to wires quality, conductivity, as well as efficiency of inverter and solar panel. So, losses must be taken into consideration in this lead.

$$\text{Average daily consumption} = 35.67 \times 1.3 = 46.37 \text{ Kwh / day}$$

So the size of PV system It can be calculated through the following:

$$\text{size of PV system} = \frac{\text{Average daily consumption}}{\text{average solar radiation}}$$

$$\text{size of PV system} = \frac{46.37}{5.93}$$

$$\text{size of PV system} = 7.81 \text{ Kwh / day}$$

Calculate several modules:

The capacity of solar panels will be used at the project (PVsyst) is (550 w or 0.55 kw).

$$\text{The number of modules} = \frac{\text{size of PV system}}{\text{capacity of the module}}$$

$$\text{The number of modules} = \frac{7.81}{0.55}$$

$$\text{The number of modules} = 14.2 = 15$$

E) Build a solar system (PV system) using PVsyst software

The photovoltaic system will be built for this school and we will try to exploit the largest possible area of the school's roof, using components of the photovoltaic system that are available in the Palestinian market and are of excellent quality.

System Data.

Some information related to the site where the photovoltaic system is intended to be built is entered into PVsyst software, such as the construction site and the construction drawing (AutoCAD for the building).

The information entered into PVsyst software is shown in the table (3.4)

Table (3.4) information entered into PVsyst software for Al-Tahrir Boys School

Coordinates	31.62007466621713, 35.15458924381167
Tilt Angle	20°
Azimuth Angle	-8°
Altitude	952 m

Tilt Angle: It represents the angle of inclination of the board from the surface, and it ranges between 20° and 23°, depending on the location and region. In this location, the angle of 20° was found to be appropriate.

Azimuth Angle: It represents the angle of inclination of the panels from the south. They can be directly with the south at an angle of 0°, or they can be rotated with the deviation of the moon from the south, which here is -8°, in order to exploit the largest surface area.

Solar cell and on Grid Inverter used in the system and the characteristics of each. However the characteristics of the solar cell and grid inverter used in the system are provided in tables 3.5 and 3.6.

The system characteristics are used in the installation of any photovoltaic system, to calculate the capacity of the system, calculate the minimum and a maximum number of cells that can be connected in series and parallel, calculate the output current and voltage, and compare them with the inverter loads that they bear.

Table(3.5) Specification of solar PV modules for Al-Tahrir Boys School

specifications	Amount
Number of panels	74
Module area	193 m²
Maximum power (pmax)	550 W
Solar Module type	Trina Solar 550W Bifacial Dual Glass
System capacity	40.7 KWp
The voltage at Maximum Power (Vmpp)	31.8 V
Current at Maximum Power (Impp)	17.29 A

Open Circuit Voltage (Voc)	38.1 V
Short Circuit Current (Isc)	18.39 A
Panel Efficiency (%)	21 %
Maximum system voltage	1500 VDC
Cell Type	Mono – Crystalline
Panel dimension (m)	2.384 × 1.096 × 0.035 m
Panel area (m ²)	2.613 m²
Panel weight (Kg)	32.6 kg
Operating Temperature C	-40°C ~+ 85°C

In the tables (3.6) and (3.7) are the characteristics of inverter used in a school project.

Table (3.6) : Characteristics of the first Inverter for Al-Tahrir Boys School

Characteristics of the first Inverter . Al-Tahrir Boys School	
System capacity	40.7 kW
Manufacturer	SMA
(ABB Solar inverters) Type code	Sunny Tripower 2000TLEE- JP
General data	
Dimension	661 × 682 × 264 mm
Weight	61 kg
Operating temperature range	-25 °C to +60 °C
Input(DC)	
Absolute Maximum Input voltage (Vmax, ab)	1000 V
Number of independent(MPPT inputs/string per MPPT)	2MPPT/2 String
Maximum Input power for each MPPT(Pmppt, max)	20440w

MPP Input DC Voltage Range(VMPPT, min)- (VMPPT,MAX)	240- 800 V
Maximum DC Input Current for each MPPT(Idc, max) /MPPT	33A
Maximum Short Circuit Current for each MPPT(ISC)	43A
Output(AC)	
Maximum AC output power	3 Phase
Rated AC Power(Pacr)	20000w
Maximum AC Output power(Pac, max)	20000w
Rated AC Output voltage(Vacr)	230 V
Maximum AC Output current(Iac, max)	29A
Rated output Frequency(Fr)	50HZ/55 HZ
Maximum Efficiency	98.4%

Table (3.7) : Characteristics of the second Inverter for Al-Tahrir Boys School.

Characteristics of the second Inverter . Al-Tahrir Boys School	
System capacity	40.7 kW
Manufacturer	SMA
(ABB Solar inverters)Type code	Sunny Tripower 15000TLEE- JP
General data	
Dimension	661 ×682 ×264 mm
Weight	61 kg
Operating temperature range	-25 °C to +60 °C
Input(DC)	
Absolute Maximum Input voltage(Vmax, ab)	1000 V
Number of independent(MPPT inputs/string per MPPT)	2MPPT/2 String
Maximum Input power for each MPPT (Pmppt, max)	15330w

MPP Input DC Voltage Range(VMPPT, min)- (VMPPT,MAX)	240- 800 V
Maximum DC Input Current for each MPPT(Idc, max) /MPPT	33A
Maximum Short Circuit Current for each MPPT(ISC)	43A
Output(AC)	
Maximum AC output power	3 Phase
Rated AC Power(Pacr)	15000w
Maximum AC Output power(Pac, max)	15000w
Rated AC Output voltage(Vacr)	230 V
Maximum AC Output current(Iac, max)	29A
Rated output Frequency(Fr)	50HZ/55 HZ
Maximum Efficiency	98.4%

The PV array is connected at all locations to the inverter through a DC junction box. From characteristics of the inverter are used as follows: It consists of 2MPPT Where each MPPT Will range of maximum input dc voltage is 240- 800V and the Maximum DC Input current is 31.8 A.

Calculate the maximum and minimum module per string.

The minimum and maximum limits of PV panels in strings that are connected together in series can be calculated in the following way:

$$\text{Maximum modules per string in series} = \frac{\text{Maximum input DC voltage to MPPT}}{\text{Rated voltage of module}}$$

$$\text{Maximum modules per string in series} = \frac{800}{31.8}$$

$$\text{Maximum modules per string in series} = 25$$

$$\text{Minimum modules per string in series} = \frac{\text{Minimum input DC voltage to MPPT}}{\text{Rated voltage of module}}$$

$$\text{Minimum modules per string in series} = \frac{240}{31.8}$$

$$\text{Minimum modules per string in series} = 7$$

Table (3.8) First and second Inverter String for Al-Tahrir Boys School.

MPPT	String number1	String number2	VMPPT (V)	Idc (A)	Idc (A)cells in three-string parallel
First Inverter 2MPPT/ 2 String					
MPPT (1)	22 cell series	22 cell Series	$22 \times 38.1 (V_{oc}) = 838.2V$	18.39A	$18.39 \times 2 = 36.78A$
second Inverter 2MPPT/ 2 String					
MPPT (1)	15 cell series	15 cell series	$15 \times 38.1 (V_{oc}) = 571.5V$	18.39A	$18.39 \times 2 = 36.78A$
Number of the cells = 22 + 22 + 15 + 15 = 74 cell					

The figures (3.3) and (3.4) show the distribution of photovoltaic panels on the roof of Al-Tahrir Boys School.

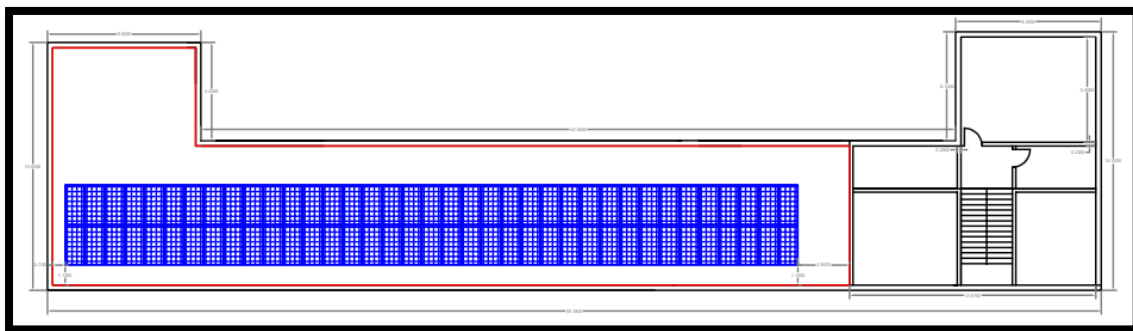

Fig.(3.3) distribution of photovoltaic panels on the roof of a Al-Tahrir Boys School.

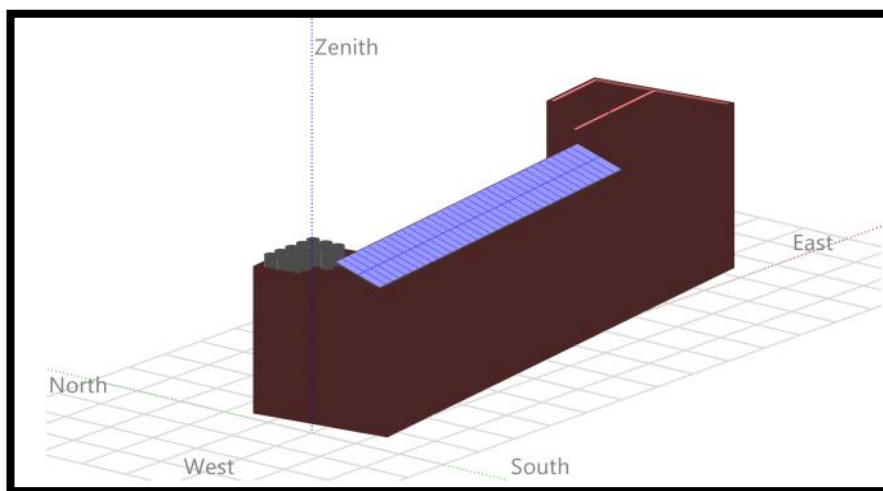

Fig.(3.4) Perspective of the PV-field and surrounding shading scene on the roof of a Al-Tahrir Boys School.

F) Energy output and Calculate revenues and payback period for the project.

The energy produced annually is (theoretically) Using the PVsyst software on a Al-Tahrir Boys School roof as shown in the table (3.9) and Fig.(3.5).

Table (3.9) Monthly AC Production for Al-Tahrir Boys School.

Month	Monthly AC Production(Kwh)
Jan	4319
Feb	4491
Mar	5852
Apr	6318
May	6882
Jun	7206
Jul	6877
Aug	6647
Sep	6017
Oct	5170
Nov	4275
Dec	3941
Annually	67995

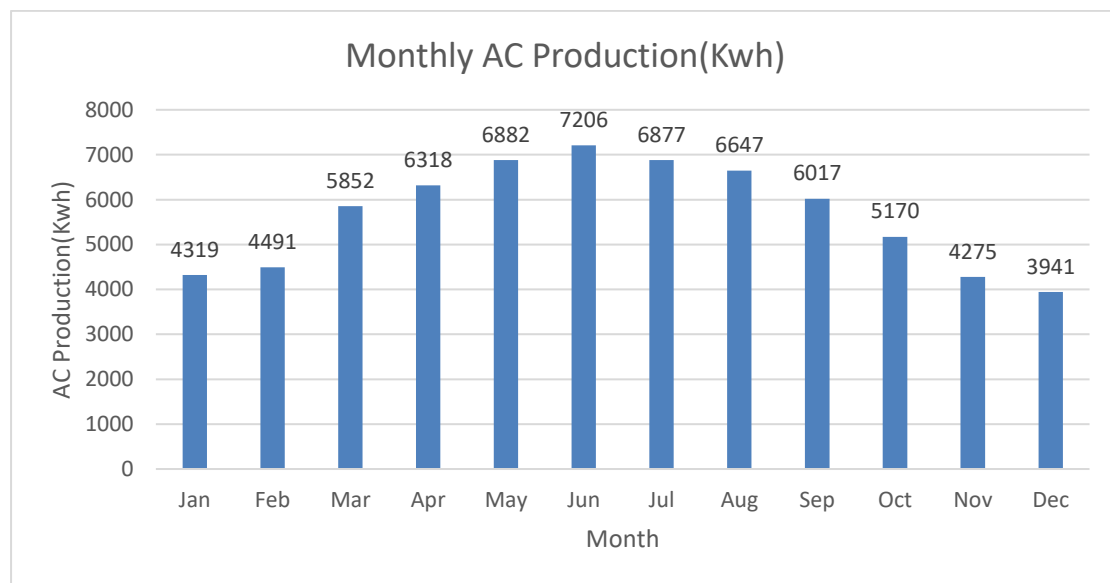

Fig.(3.5) Monthly AC Production for Al-Tahrir Boys School.

Observations of the monthly output of the system on the roof of the school, and the monthly consumption amount of electricity can be shown in the figure (3.6).

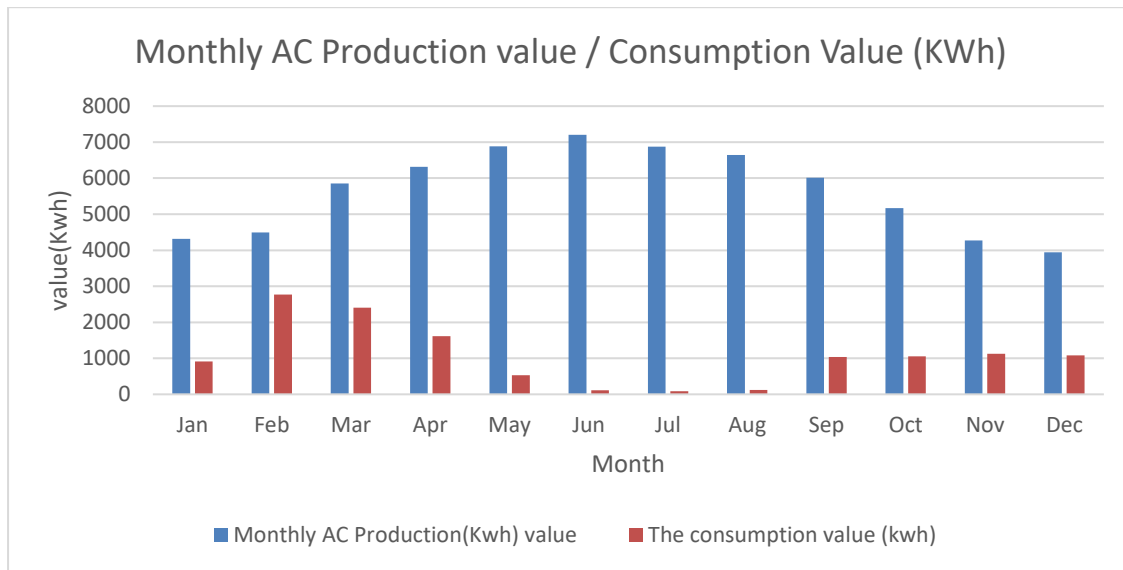

Fig.(3.6) Monthly AC Production / Consumption Value (KWh)for Al-Tahrir Boys School.

From the results shown in Figure (3.6) it was found that the difference between consumption and production is large and this is due to the absence of energy-consuming electrical systems in Palestinian schools, such as heating and cooling systems, as the weather in Palestine in the spring, summer and autumn seasons does not need cooling systems in schools as the weather is moderate.

Table (3.10) and Figure(3.7) shows The AC surplus value (KWh), which is calculated by subtracting the monthly consumption value from the monthly production value.

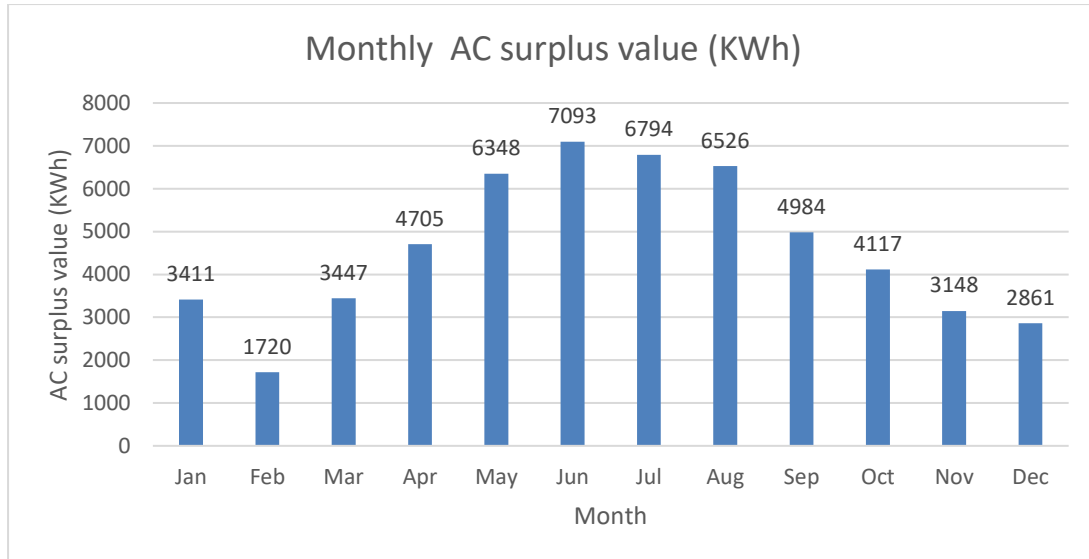

Fig.(3.7) Monthly The AC surplus value (KWh)for Al-Tahrir Boys School.

Table(3.10) Monthly The AC surplus value (KWh)for Al-Tahrir Boys School.

Month	The AC surplus value (KWh)
Jan	3411
Feb	1720
Mar	3447
Apr	4705
May	6348
Jun	7093
Jul	6794
Aug	6526
Sep	4984
Oct	4117
Nov	3148
Dec	2861
Annually	55154

By subtracting the consumed value from the produced value, 55154 KWh will be the AC surplus value for 12 months.

Calculating the revenues from selling surplus energy annually.

It is possible to calculate the selling price of energy surplus to the school’s annual need, which is considered the project’s annual profits. It is known that the price of a kilowatt hour (1 Kwh) is sold at a price 0.16 USD approximately equivalent to 0.56 NIS.

Annual revenue = The AC surplus value (KWh) × price of a kilowatt hour (1 Kwh)

$$\text{Annual revenue} = 55154 \times 0.56$$

Annual revenue = 30886.24 NIS

Project cost calculation.

Knowing the costs of establishing the project depends on several factors, including the size of the project and the types of materials and solar panels used in the project.

The total cost of the project = cell capacity × number of cells × Kilowatt price in NIS

$$\text{The total cost of the project} = 0.55 \times 74 \times 4200$$

The total cost of the project = 170940 NIS

Total income over 20 years and Payback period.

If the expected life of the project is 20 years, the project will achieve revenues of up to 617724.8 NIS , as shown in the Figure (3.8) .

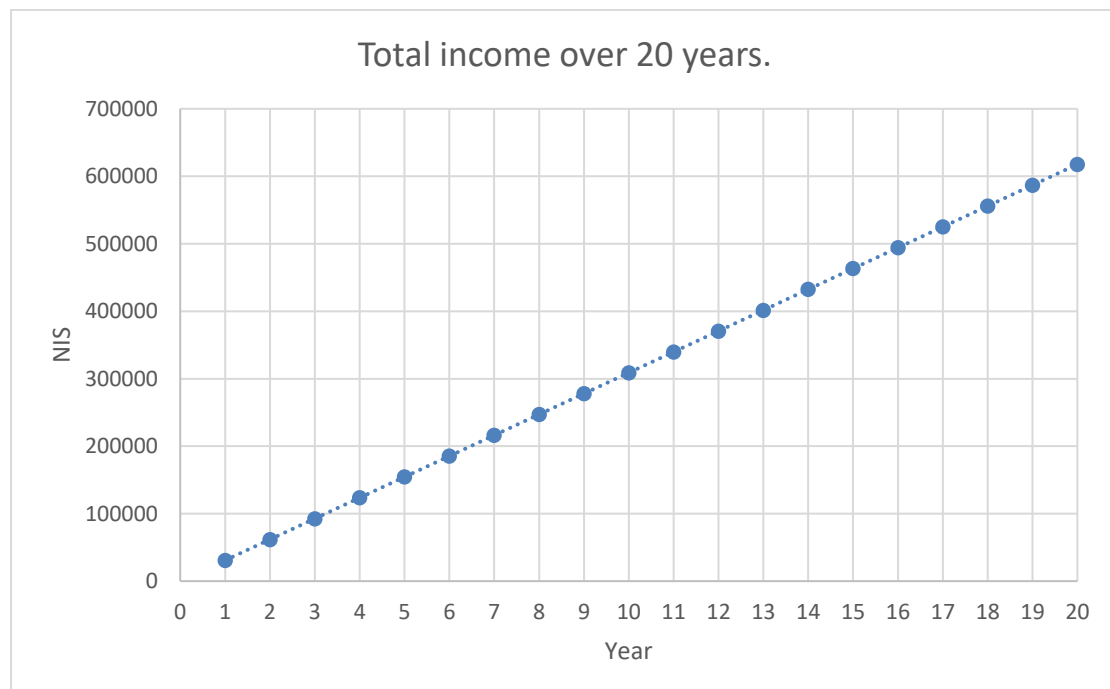

Fig.(3.8) Total income over 20 years for Al-Tahrir Boys School.

Now the project's payback can be determined by knowing the project cost and the project's annual income.

$$\text{Payback period} = \frac{\text{Total income over 20 years}}{\text{The total cost of the project}}$$

$$\text{Payback period} = \frac{617724.8}{170940}$$

$$\text{Payback period} = 3.61 \text{ year}$$

G) Conclusion

Al-Tahrir Boys School is a medium space school, it has an available area for the PV panels of 193 m² of the total area 394 m². The calculation shows that it's roof could handle a PV system of 40.7 KW, about 74 PV panels. And this will produce annually 55154 KWh of surplus electricity, were the total annual consumption is 12841 KWh. That means annually income will be 30886.24 NIS and the total cost of the system about 170940 NIS. After making calculations the payback period will be 3.61 years, and the school will produce a total income after 20 years which is the life span of the system about 617724.8 NIS.

3.2.2 Beit Fajjar Secondary Girls School Result.

A) Technical and engineering information and electricity consumption for the Beit Fajjar Secondary Girls School.

Technical and engineering information and electricity consumption for the Beit Fajjar Secondary Girls School in Table (3.11) were obtained with the assistance of the Ministry of Education - Bethlehem and the Electricity Company.

Table 3.11: Beit Fajjar Secondary Girls School building specifications

Type of building	Girls school students
Owner of building	The Ministry of Education
Location	Palestine - Bethlehem - Beit Fajjar
Number of floors	4 floors
The monthly bill ranges	182 -971 NIS
The surface area of the school	780 m ²

B) Electricity consumption.

Table (3.12) and Fig.(3.9) show the school annual electricity consumption and its financial cost. We need this information and use it to calculate the capacity of the system needed to cover the school's needs and financial cost.

Table 3.12: Electricity consumption and financial cost (kWh and NIS) for Beit Fajjar Secondary Girls School.

Month	Meter reading	The consumption value (kwh)	The bill value (NIS)
Jan-19	1689	903	626
Feb-19	1684	750	514
Mar-19	1577	620	407
Apr-19	1120	830	665
May-19	1732	550	354
Jun-19	1659	300	182
Jul-19	1622	300	182
Aug-19	1528	1060	749
Sep-19	1642	1340	971
Oct-19	1886	1000	650
Nov-19	1985	900	621
Dec-19	1986	902	623
Annual total		9455	6544

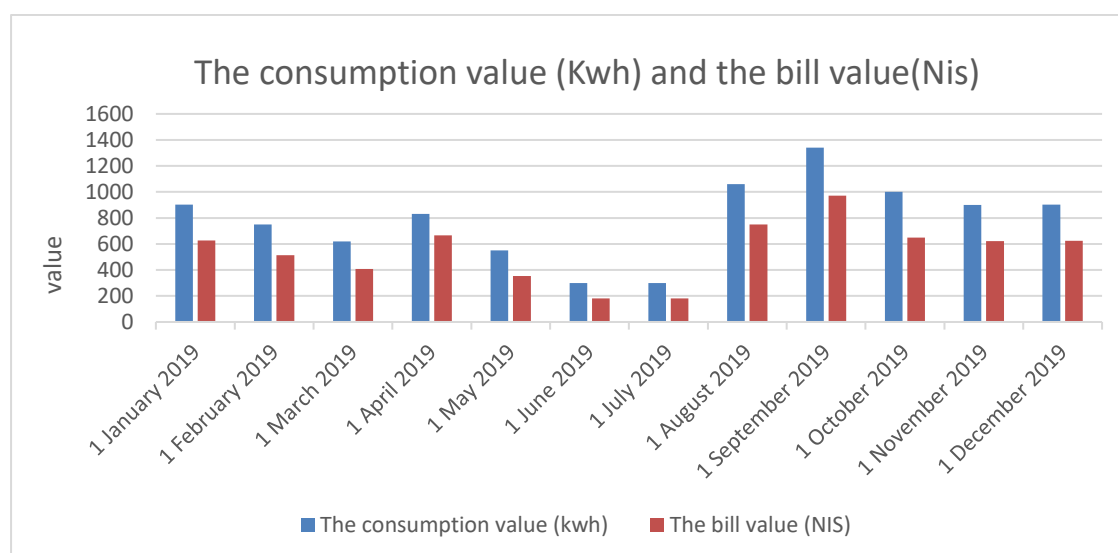

Fig.(3.9) : Electricity consumption and financial cost (kWh and NIS) for Beit Fajjar Secondary Girls School.

C) Distribution of the Ret screen in Palestine

Monthly global solar insolation and daily average bright sunshine hours in Bethlehem-Beit Fajjar are presented in table (3.13). These values are an average of solar insolation from an expert Ret screen program.

Table 3.13: Monthly global solar insolation at Bethlehem-Beit Fajjar.

Month	Solar insolation (KWh/m ² .day)
January	3.37
February	4.20
March	5.30
April	6.81
May	7.88
June	8.57
July	8.40
August	7.85
September	6.73
October	5.28
November	3.74
December	3.05
Total /year	71.13
Average insolation	5.93

By using the Ret Screen program, the average solar radiation in Beit Fajjar = 5.93 kwh/m².day.

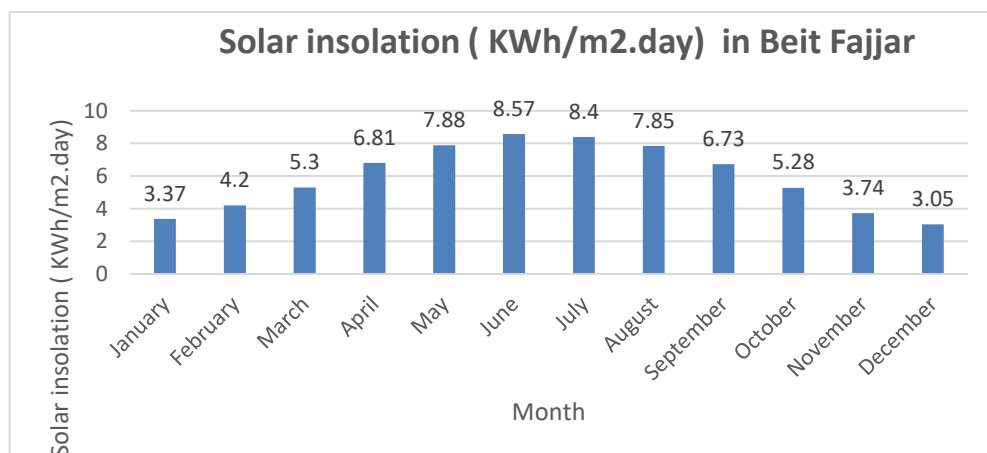

Fig.(3.10) : Solar insolation (KWh/m².day) in Beit Fajjar

D) The size of solar power system.

Based on the school's monthly consumption quantity, it is necessary to calculate the amount of the photovoltaic system that must be sufficient to meet the school's need for electrical energy. To know this, we must do the following calculations within the monthly consumption quantity and the specifications of the system that will be designed.

Calculate Average monthly consumption:

$$\text{Average monthly consumption} = \frac{\text{Total consumption at annual (Kwh)}}{12 \text{ month}}$$

$$\text{Average monthly consumption} = \frac{9455}{12}$$

$$\text{Average monthly consumption} = 787.91 \text{ Kwh / month}$$

Calculate Average daily consumption:

$$\text{Average daily consumption} = \frac{\text{Average monthly consumption}}{\text{days}}$$

$$\text{Average daily consumption} = \frac{787.91}{30}$$

$$\text{Average daily consumption} = 26.26 \text{ Kwh / day}$$

But The losses can reach up to (1.3) due to wires quality, conductivity, as well as efficiency of inverter and solar panel . so, losses must be taken into consideration in this lead.

$$\text{Average daily consumption} = 26.26 \times 1.3 = 34.13 \text{ Kwh / day}$$

So the size of PV system It can be calculated through the following :

$$\text{size of PV system} = \frac{\text{Average daily consumption}}{\text{average solar radiation}}$$

$$\text{size of PV system} = \frac{34.13}{5.93}$$

$$\text{size of PV system} = 5.75 \text{ Kwh / day}$$

Calculate several modules:

the capacity of solar panels will be used at the project (PVsyst) is (550 w or 0.55 kw).

$$\text{The number of modules} = \frac{\text{size of PV system}}{\text{capacity of the module}}$$

$$\text{The number of modules} = \frac{5.75}{0.55}$$

$$\text{The number of modules} = 10.45 = 11$$

E) Build a solar system (PV system) using PVsyst software

The photovoltaic system will be built for this school and we will try to exploit the largest possible area of the school’s roof, using components of the photovoltaic system that are available in the Palestinian market and are of excellent quality.

System Data.

Some information related to the site where the photovoltaic system is intended to be built is entered into PVsyst software, such as the construction site and the construction drawing (AutoCAD for the building).

The information entered into PVsyst software is shown in the table (3.14)

Table (3.14) information entered into PVsyst software for Beit Fajjar Secondary Girls School.

Coordinates	31.622246780854997, 35.14828468600633
Tilt Angle	20°
Azimuth Angle	5°
Altitude	907 m

Tilt Angle : It represents the angle of inclination of the board from the surface, and it ranges between 20° and 23°, depending on the location and region. In this location, the angle of 20° was found to be appropriate.

Azimuth Angle: It represents the angle of inclination of the panels from the south. They can be directly with the south at an angle of 0°, or they can be rotated with the deviation of the moon from the south, which here is 5°, in order to exploit the largest surface area.

Solar cell and On Grid Inverter used in the system and the characteristics of each.

Solar cell specifications

The specifications of the installed solar PV modules are shown in Table 3.15 . The system characteristics are used in the installation of any photovoltaic system, to calculate the capacity of the system, calculate the minimum and a maximum number of cells that can be connected in series and parallel, calculate the output current and voltage, and compare them with the inverter loads that they bear.

Table(3.15) Specification of solar PV modules Table for Beit Fajjar Secondary Girls School.

specifications	Amount
Number of panels	160
Module area	418 m²
Maximum power (pmax)	550 W
Solar Module type	Trina Solar 550W Bifacial Dual Glass
System capacity	88 KWp
The voltage at Maximum Power (Vmpp)	31.8 V
Current at Maximum Power (Impp)	17.29 A
Open Circuit Voltage (Voc)	38.1 V
Short Circuit Current (Isc)	18.39 A
Panel Efficiency (%)	21 %
Maximum system voltage	1500 VDC
Cell Type	Mono – Crystalline
Panel dimension (m)	2.384 × 1.096 × 0.035 m
Panel area (m ²)	2.613 m²
Panel weight (Kg)	32.6 kg
Operating Temperature C	-40°C ~+ 85°C

On Grid Inverter

Characteristics of the second Inverter (20 kW) . Beit Fajjar Secondary Girls School.	
System capacity	88 kW
Manufacturer	SMA
(ABB Solar inverters) Type code	Sunny Tripower 20000TL-30
General data	
Dimension	661 ×682 ×264 mm
Weight	61 kg
Operating temperature range	-25 °C to +60 °C
Input(DC)	
Absolute Maximum Input voltage (V _{max, ab})	1000 V
Number of independent(MPPT inputs/string per MPPT)	2MPPT/2 String
Maximum Input power for each MPPT(P _{mppt, max})	20440w
MPP Input DC Voltage Range(V _{MPPT, min})- (V _{MPPT,MAX})	320- 800 V
Maximum DC Input Current for each MPPT(I _{dc, max}) /MPPT	33A
Maximum Short Circuit Current for each MPPT(ISC)	43A
Output(AC)	
Maximum AC output power	3 Phase
Rated AC Power(P _{acr})	20000w
Maximum AC Output power(P _{ac, max})	20000w
Rated AC Output voltage(V _{acr})	230 V
Maximum AC Output current(I _{ac, max})	29A
Rated output Frequency(Fr)	50HZ/55 HZ
Maximum Efficiency	98.4%

In the tables (3.16) and (3.17) are the characteristics of inverter used in a school project.

Table (3.16) : Characteristics of the first Inverter for Beit Fajjar Secondary

Characteristics of the first Inverter (50 KW) . Beit Fajjar Secondary Girls School.	
System capacity	88 kW
Manufacturer	SMA
(ABB Solar inverters) Type code	Sunny Tripower 75000-CORE1
General data	
Dimension(W/H/D)	569 ×733 ×621 mm
Weight	84 kg
Operating temperature range	-25 °C to +60 °C
Input(DC)	
Absolute Maximum Input voltage (Vmax, ab)	1000 V
Number of independent(MPPT inputs/string per MPPT)	6MPPT/6 String
Maximum Input power for each MPPT(Pmppt, max)	75000w
MPP Input DC Voltage Range(VMPPT, min)- (VMPPT,MAX)	500- 670 V
Maximum DC Input Current for each MPPT(Idc, max) /MPPT	20A
Maximum Short Circuit Current for each MPPT(ISC)	30A
Output(AC)	
Maximum AC output power	3 Phase
Rated AC Power(Pacr)	50000w
Maximum AC Output power(Pac, max)	20000w
Rated AC Output voltage(Vacr)	230 V
Maximum AC Output current(Iac, max)	72.5A
Rated output Frequency(Fr)	50HZ/55 HZ
Maximum Efficiency	98.1%

Table (3.17) : Characteristics of the second Inverter for Beit Fajjar Secondary Girls School.

Connecting the photovoltaic panels and the general geometry of the project.

The PV array is connected at all locations to the inverter through a DC junction box.

Strings for solar PV module:

First inverter:

From characteristics of the first inverter are used as follows: It consists of 6MPPT

Where each MPPT Will range of maximum input dc voltage is 500- 670V and the

Maximum DC Input current is 31.8 A.

Calculate the maximum and minimum module per string.

The minimum and maximum limits of PV panels in strings that are connected together in series can be calculated in the following way:

$$\text{Maximum modules per string in series} = \frac{\text{Maximum input DC voltage to MPPT}}{\text{Rated voltage of module}}$$

$$\text{Maximum modules per string in series} = \frac{670}{31.8}$$

$$\text{Maximum modules per string in series} = 21$$

$$\text{Minimum modules per string in series} = \frac{\text{Minimum input DC voltage to MPPT}}{\text{Rated voltage of module}}$$

$$\text{Minimum modules per string in series} = \frac{500}{31.8}$$

$$\text{Minimum modules per string in series} = 16$$

Second inverter:

From characteristics of the inverter are used as follows: It consists of 2MPPT Where each MPPT Will range of maximum input dc voltage is 320- 800V and the Maximum

DC Input current is 31.8 A.

Calculate the maximum and minimum module per string.

The minimum and maximum limits of PV panels in strings that are connected together in series can be calculated in the following way:

$$\text{Maximum modules per string in series} = \frac{\text{Maximum input DC voltage to MPPT}}{\text{Rated voltage of module}}$$

$$\text{Maximum modules per string in series} = \frac{800}{31.8}$$

$$\text{Maximum modules per string in series} = 25$$

$$\text{Minimum modules per string in series} = \frac{\text{Minimum input DC voltage to MPPT}}{\text{Rated voltage of module}}$$

$$\text{Minimum modules per string in series} = \frac{320}{31.8}$$

$$\text{Minimum modules per string in series} = 10$$

Table(3.18) First and second Inverter String for Beit Fajjar Secondary Girls

School

MPPT	String number1	String number2	VMPPT (V)	Idc (A)	Idc (A)cells in three-string parallel
First Inverter 6MPPT/ 2 String					
MPPT (1)	19 cell series	19 cell Series	19×38.1(Voc)=723.9 V	18.39A	18.39×2=36.78A
MPPT (2)	19 cell series	19 cell series	19×38.1(Voc)=723.9 V	18.39A	18.39×2=36.78A
MPPT (3)	19 cell series	19 cell series	19×38.1(Voc)=723.9 V	18.39A	18.39×2=36.78A
second Inverter 2MPPT/ 2 String					
MPPT (1)	23 cell series	23 cell series	23×38.1 (Voc)=876.3V	18.39A	18.39×2=36.78A
Number of the cells =(6× 19)+23 + 23 = 160 cell					

The figures (3.11) and (3.12) show the distribution of photovoltaic panels on the roof of Beit Fajjar Secondary Girls School

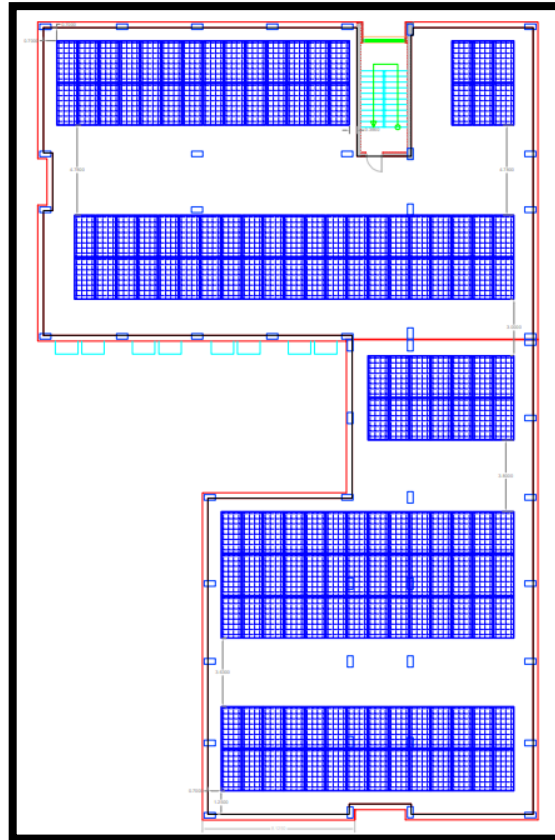

Fig.(3.11) distribution of photovoltaic panels on the roof of a Beit Fajjar Secondary Girls School.

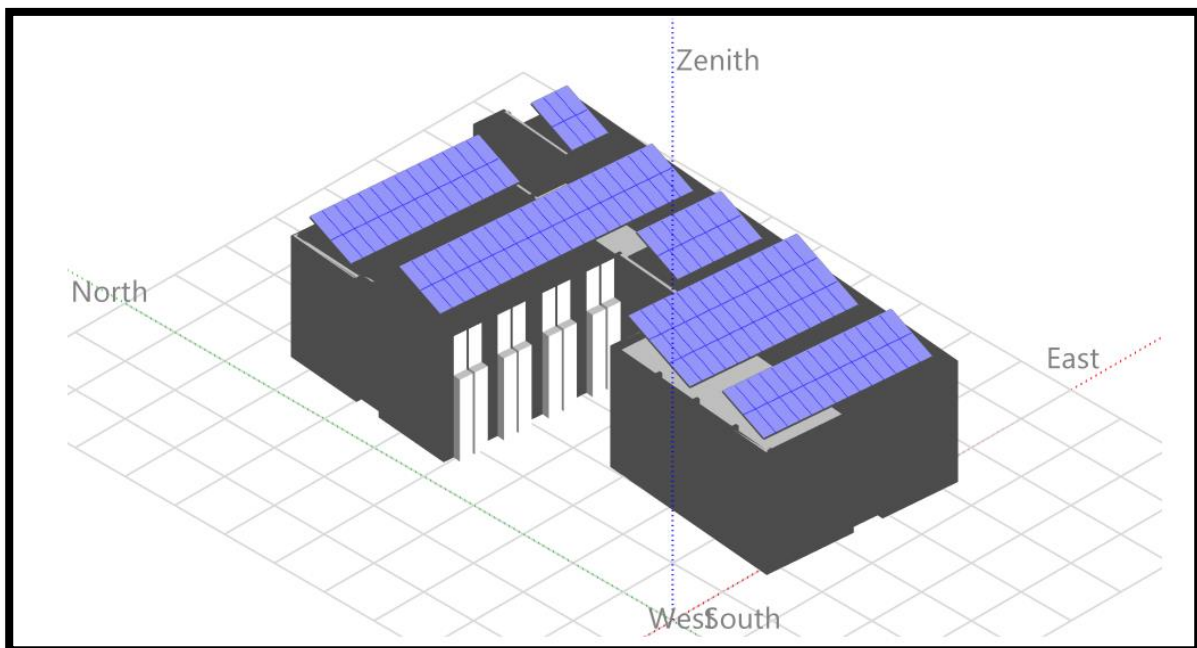

Fig.(3.12) Perspective of the PV-field and surrounding shading scene on the roof of a Beit Fajjar Secondary Girls School.

F) Energy output and Calculate revenues and payback period for the project.

The energy produced annually is (theoretically) Using the PVsyst software on a Beit Fajjar Secondary Girls School roof as shown in the table (3.19) and Fig.(3.13).

Table (3.19) Monthly AC Production for Beit Fajjar Secondary Girls School.

Month	Monthly AC Production(Kwh)
Jan	9313
Feb	9665
Mar	12515
Apr	13517
May	14782
Jun	15535
Jul	14807
Aug	14319
Sep	12831
Oct	11103
Nov	9170
Dec	8433
Annually	145990

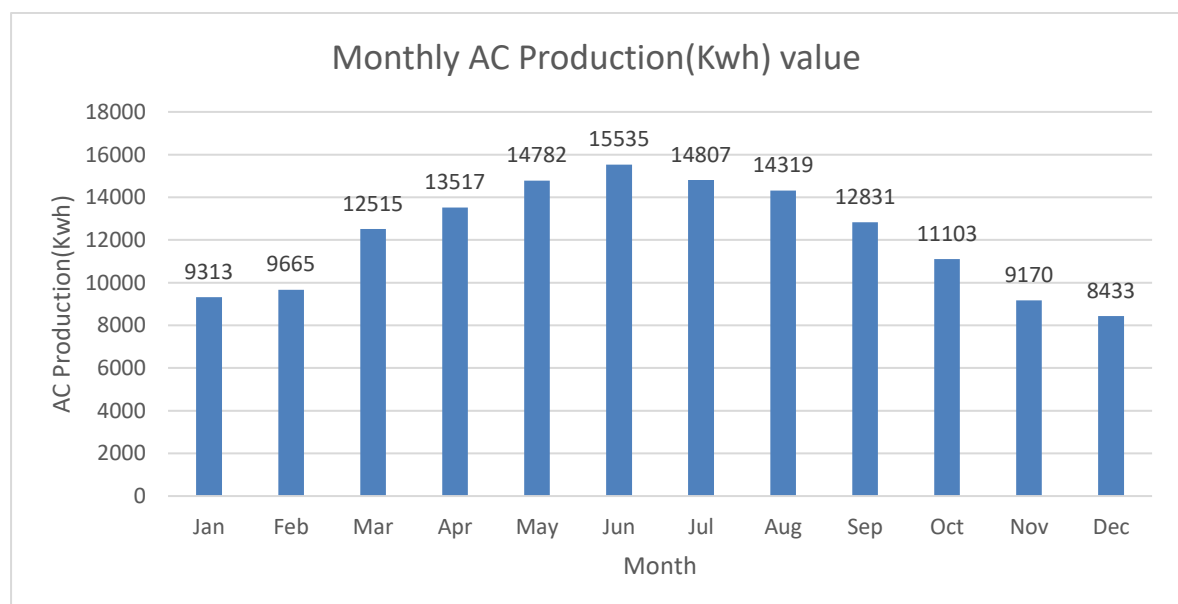

Fig.(3.13) Monthly AC Production for Beit Fajjar Secondary Girls School..

Observations of the monthly output of the system on the roof of the school, and the monthly consumption amount of electricity can be shown in the figure (3.14).

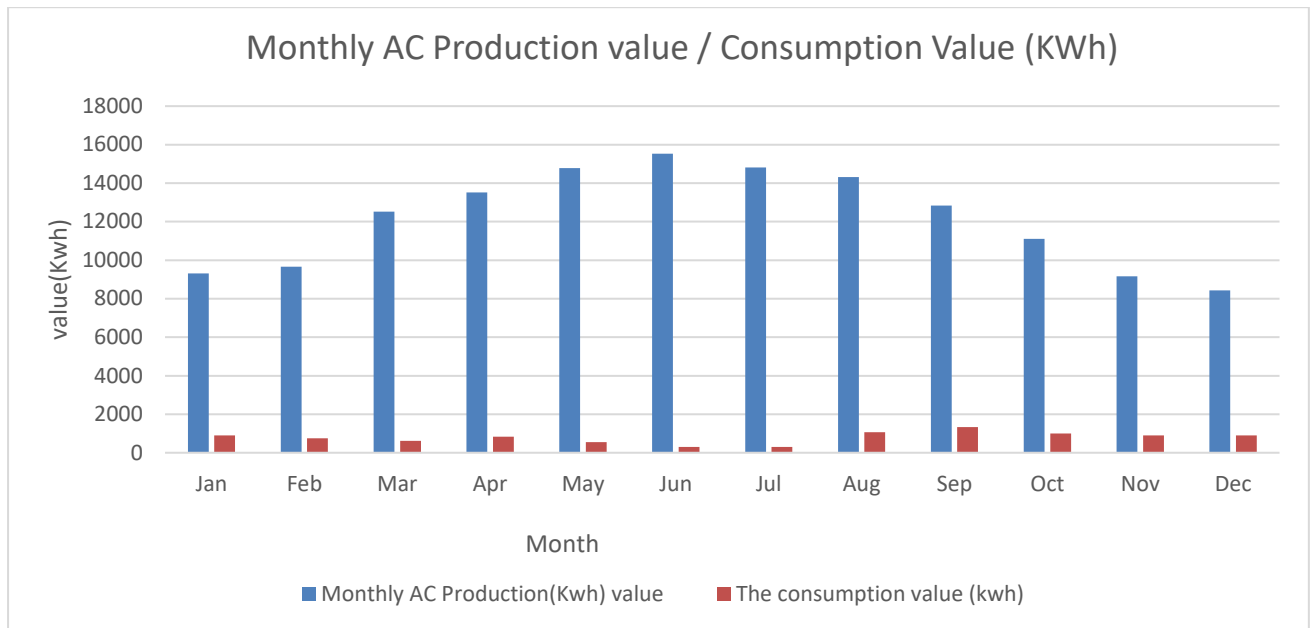

Fig.(3.14) Monthly AC Production / Consumption Value (KWh)for Beit Fajjar Secondary Girls School.

From the results shown in Figure (3.14) it was found that the difference between consumption and production is large and this is due to the absence of energy-consuming electrical systems in Palestinian schools, such as heating and cooling systems, as the weather in Palestine in the spring, summer and autumn seasons does not need cooling systems in schools as the weather is moderate.

The Table (3.20) and Figure(3.15) shows The AC surplus value (KWh), which is calculated by subtracting the monthly consumption value from the monthly production value.

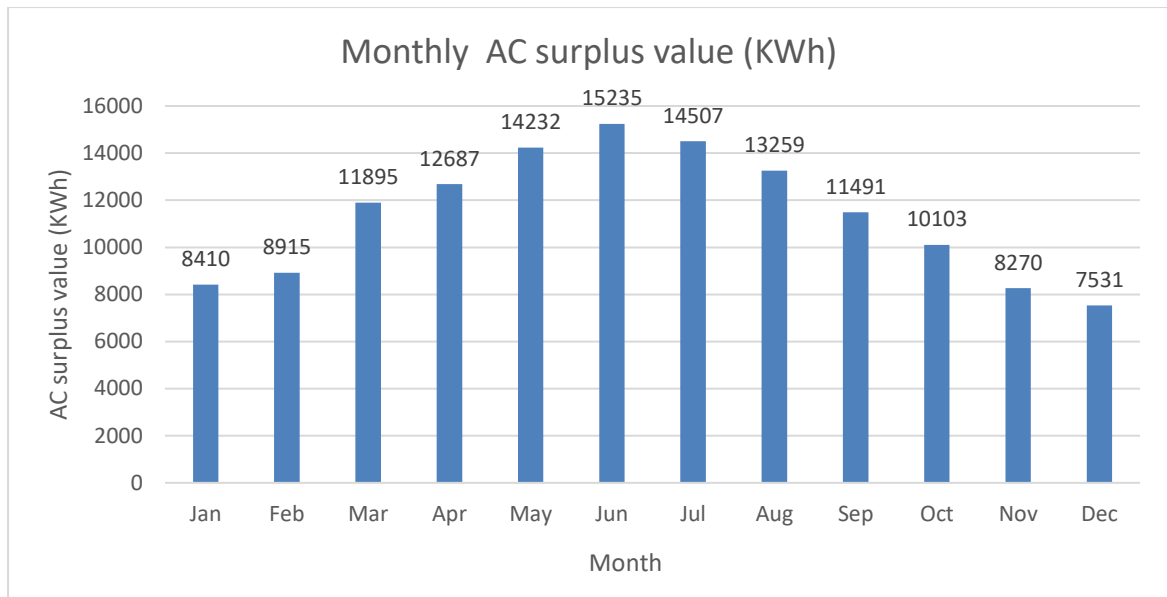

Fig.(3.15) Monthly The AC surplus value (KWh)for Beit Fajjar Secondary Girls School.

Table(3.20) Monthly The AC surplus value (KWh)for Beit Fajjar Secondary Girls School.

Month	The AC surplus value (KWh)
Jan	8410
Feb	8915
Mar	11895
Apr	12687
May	14232
Jun	15235
Jul	14507
Aug	13259
Sep	11491
Oct	10103
Nov	8270
Dec	7531
Annually	136535

By subtracting the consumed value from the produced value, 136535 KWh will be the AC surplus value for 12 months.

Calculating the revenues from selling surplus energy annually.

It is possible to calculate the selling price of energy surplus to the school's annual need, which is considered the project's annual profits. It is known that the price of a kilowatt hour (1 Kwh) is sold at a price 0.16 USD approximately equivalent to 0.56 NIS.

Annual revenue = The AC surplus value (KWh) × price of a kilowatt hour (1 Kwh)

$$\text{Annual revenue} = 136535 \times 0.56$$

Annual revenue = 76459.6 NIS

Project cost calculation.

Knowing the costs of establishing the project depends on several factors, including the size of the project and the types of materials and solar panels used in the project.

The total cost of the project = cell capacity × number of cells × Kilowatt price in NIS

$$\text{The total cost of the project} = 0.55 \times 160 \times 4200$$

The total cost of the project = 369600 NIS

Total income over 20 years and Payback period.

If the expected life of the project is 20 years, the project will achieve revenues of up to 1529192 NIS , as shown in the Figure (3.16) .

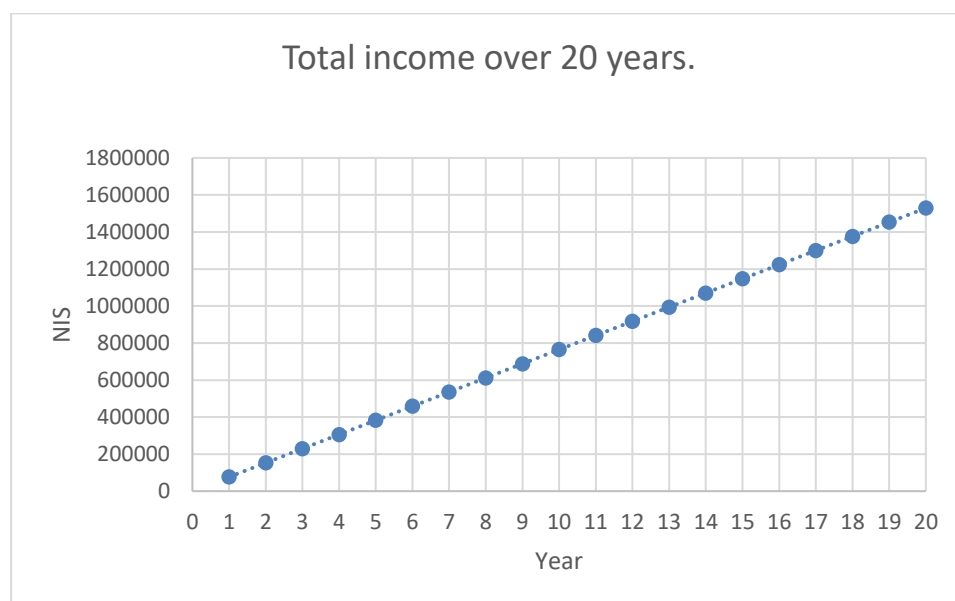

Fig.(3.16) Total income over 20 years for Beit Fajjar Secondary Girls School

Now the project's payback can be determined by knowing the project cost and the project's annual income.

$$\text{Payback period} = \frac{\text{Total income over 20 years}}{\text{The total cost of the project}}$$

$$\text{Payback period} = \frac{1529192}{369600}$$

$$\text{Payback period} = 4.13 \text{ year}$$

G) Conclusion

Beit Fajjar Secondary Girls School is a large space school, it has an available area for the PV panels of 418 m² of the total area 780 m². The calculation shows that it's roof could handle a PV system of 88 KW, about 160 PV panels. And this will produce annually 136535 KWh of surplus electricity, were the total annual consumption is 9455 KWh. That means annually income will be 76459.6 NIS and the total cost of the system about 369600 NIS. After making calculations the payback period will be 4.13 years, and the school will produce a total income after 20 years which is the life span of the system about 1529192 NIS.

3.2.3 Al-sakra primary school Result.

A) Technical and engineering information and electricity consumption for the Al-sakra primary school .

Technical and engineering information and electricity consumption for the Beit Fajjar Secondary Girls School in Table (3.21) were obtained with the assistance of the Ministry of Education - Bethlehem and the Electricity Company.

Table(3.21) Al-sakra primary school building specifications

Type of building	Mixed school students
Owner of building	The Ministry of Education
Location	Palestine - Bethlehem - Beit Fajjar
Number of floors	4 floors
The monthly bill ranges	231 -5822 NIS
The surface area of the school	616 m ²

B) Electricity consumption.

Table (3.22) and Fig.(3.17) shows the school annual electricity consumption and its financial cost. We need this information and use it to calculate the capacity of the system needed to cover the school's needs and financial cost.

Table (3.22): Electricity consumption and financial cost (kWh and NIS) for Al-sakra primary school.

Month	Meter reading	The consumption value (kwh)	The bill value (NIS)
Jan-22	1674	1288	863
Feb-22	1394	1100	750
Mar-22	1430	700	470
Apr-22	1806	399	231
May-22	1630	8086	5822
Jun-22	1641	1173	782
Jul-22	1306	572	344
Aug-22	1415	823	549
Sep-22	1427	2075	1568
Oct-22	1824	2158	1632
Nov-22	1736	2304	1750
Dec-22	1649	3054	2344
Annual total		23732	17105

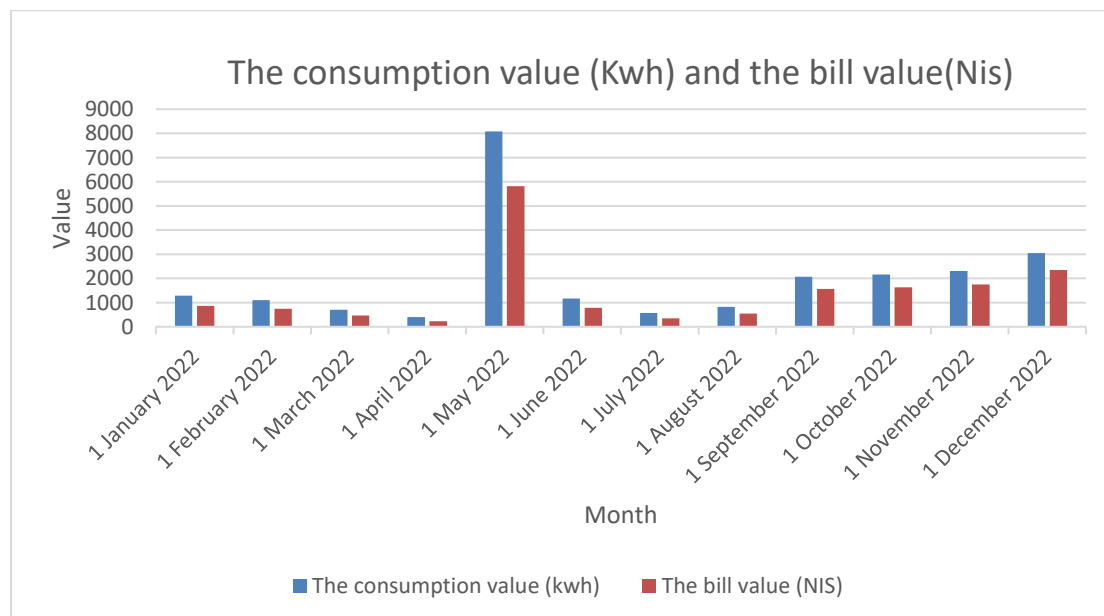

Fig.(3.17) : Electricity consumption and financial cost (kWh and NIS) for Al-sakra primary school.

C) Distribution of the Ret screen in Palestine

Monthly global solar insolation and daily average bright sunshine hours in Bethlehem-Beit Fajjar are presented in table (3.23). These values are an average of solar insolation from an expert Ret screen program

Table(3.23): Monthly global solar insolation at Bethlehem-Beit Fajjar.

Month	Solar insolation (KWh/m ² .day)
January	3.37
February	4.20
March	5.30
April	6.81
May	7.88
June	8.57
July	8.40
August	7.85
September	6.73
October	5.28
November	3.74
December	3.05
Total /year	71.13
Average insolation	5.93

By using the Ret Screen program, the average solar radiation in Beit Fajjar = 5.93 kwh/m².day.

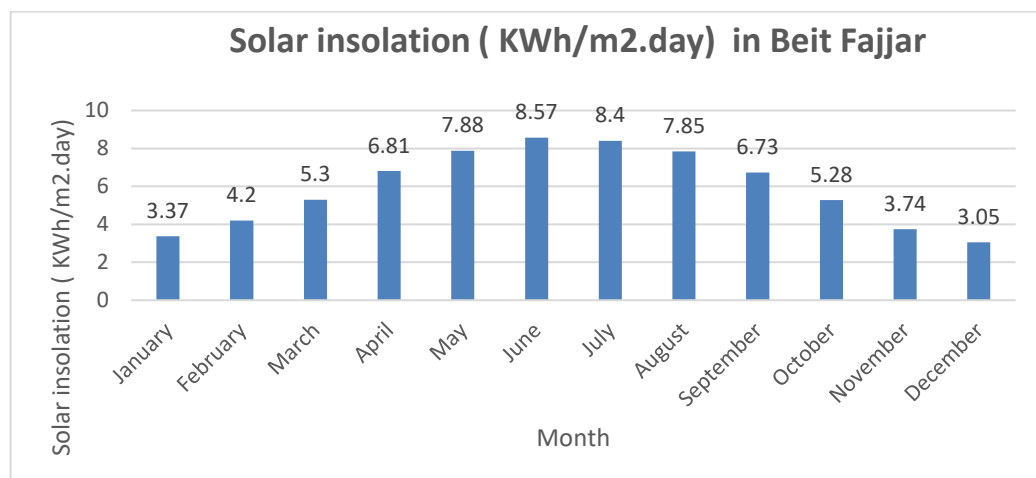

Fig.(3.18) : Solar insolation (KWh/m².day) in Beit Fajjar

D) The size of solar power system.

Based on the school's monthly consumption quantity, it is necessary to calculate the amount of the photovoltaic system that must be sufficient to meet the school's need for electrical energy. To know this, we must do the following calculations within the monthly consumption quantity and the specifications of the system that will be designed.

Calculate Average monthly consumption:

$$\text{Average monthly consumption} = \frac{\text{Total consumption at annual (Kwh)}}{12 \text{ month}}$$

$$\text{Average monthly consumption} = \frac{23732}{12}$$

$$\text{Average monthly consumption} = 1977.67 \text{ Kwh / month}$$

Calculate Average daily consumption:

$$\text{Average daily consumption} = \frac{\text{Average monthly consumption}}{\text{days}}$$

$$\text{Average daily consumption} = \frac{1977.67}{30}$$

$$\text{Average daily consumption} = 65.92 \text{ Kwh / day}$$

But The losses can reach up to (1.3) due to wires quality, conductivity, as well as efficiency of inverter and solar panel . so, losses must be taken into consideration in this lead.

$$\text{Average daily consumption} = 65.92 \times 1.3 = 85.69 \text{ Kwh / day}$$

So the size of PV system It can be calculated through the following :

$$\text{size of PV system} = \frac{\text{Average daily consumption}}{\text{average solar radiation}}$$

$$\text{size of PV system} = \frac{85.69}{5.93}$$

$$\text{size of PV system} = 14.45 \text{ Kwh / day}$$

Calculate several modules:

the capacity of solar panels will be used at the project (PVsyst) is (550 w or 0.55 kw).

$$\text{The number of modules} = \frac{\text{size of PV system}}{\text{capacity of the module}}$$

$$\text{The number of modules} = \frac{14.45}{0.55}$$

$$\text{The number of modules} = 26.27 = 27$$

E) Build a solar system (PV system) using PVsyst software

The photovoltaic system will be built for this school and we will try to exploit the largest possible area of the school’s roof, using components of the photovoltaic system that are available in the Palestinian market and are of excellent quality.

System Data.

Some information related to the site where the photovoltaic system is intended to be built is entered into PVsyst software, such as the construction site and the construction drawing (AutoCAD for the building).

The information entered into PVsyst software is shown in the table (3.24)

Table (3.24) information entered into PVsyst software for Al-sakra primary school

Coordinates	31.628844918259038, 35.161454332249754
Tilt Angle	20°
Azimuth Angle	17°
Altitude	915 m

Tilt Angle : It represents the angle of inclination of the board from the surface, and it ranges between 20° and 23°, depending on the location and region. In this location, the angle of 20° was found to be appropriate.

Azimuth Angle: It represents the angle of inclination of the panels from the south. They can be directly with the south at an angle of 0°, or they can be rotated with the deviation of the moon from the south, which here is 17°, in order to exploit the largest surface area.

Solar cell and On Grid Inverter used in the system and the characteristics of each.

Solar cell specifications

The specifications of the installed solar PV modules are shown in Table (3.25) . The system characteristics are used in the installation of any photovoltaic system, to calculate the capacity of the system, calculate the minimum and a maximum number of cells that can be connected in series and parallel, calculate the output current and voltage, and compare them with the inverter loads that they bear.

Table(3.25) Specification of solar PV modules Table for Al-sakra primary school

specifications	Amount
Number of panels	111
Module area	290 m²
Maximum power (pmax)	550 W
Solar Module type	Trina Solar 550W Bifacial Dual Glass
System capacity	61.05 KWp
The voltage at Maximum Power (Vmpp)	31.8 V
Current at Maximum Power (Impp)	17.29 A
Open Circuit Voltage (Voc)	38.1 V
Short Circuit Current (Isc)	17.29 A
Panel Efficiency (%)	21 %
Maximum system voltage	1500 VDC
Cell Type	Mono – Crystalline
Panel dimension (m)	2.384 × 1.096 × 0.035 m
Panel area (m ²)	2.613 m²
Panel weight (Kg)	32.6 kg
Operating Temperature C	-40°C ~+ 85°C

On Grid Inverter

In the table (3.26) are the characteristics of inverter used in a school project.

Table (3.26) : Characteristics of the Inverter for Al-sakra primary school.

Characteristics of the Inverter (50 KW) . Al-sakra primary school .	
System capacity	61.05 kW
Manufacturer	SMA
(ABB Solar inverters) Type code	Sunny Tripower 75000-CORE1
General data	
Dimension(W/H/D)	569 ×733 ×621 mm
Weight	84 kg
Operating temperature range	-25 °C to +60 °C
Input(DC)	
Absolute Maximum Input voltage (V _{max, ab})	1000 V
Number of independent(MPPT inputs/string per MPPT)	6MPPT/6 String
Maximum Input power for each MPPT(P _{mppt, max})	75000w
MPP Input DC Voltage Range(V _{MPPT, min})-(V _{MPPT,MAX})	500- 670 V
Maximum DC Input Current for each MPPT(I _{dc, max}) /MPPT	20A
Maximum Short Circuit Current for each MPPT(ISC)	30A
Output(AC)	
Maximum AC output power	3 Phase
Rated AC Power(P _{acr})	50000w
Maximum AC Output power(P _{ac, max})	20000w
Rated AC Output voltage(V _{acr})	230 V
Maximum AC Output current(I _{ac, max})	72.5A
Rated output Frequency(Fr)	50HZ/55 HZ
Maximum Efficiency	98.1%

***Connecting the photovoltaic panels and the general geometry of the project.**

The PV array is connected at all locations to the inverter through a DC junction box.

Strings for solar PV module:

From characteristics of the first inverter are used as follows: It consists of 6MPPT

Where each MPPT Will range of maximum input dc voltage is 500- 670V and the

Maximum DC Input current is 31.8 A.

Calculate the maximum and minimum module per string.

The minimum and maximum limits of PV panels in strings that are connected together in series can be calculated in the following way:

$$\text{Maximum modules per string in series} = \frac{\text{Maximum input DC voltage to MPPT}}{\text{Rated voltage of module}}$$

$$\text{Maximum modules per string in series} = \frac{670}{31.8}$$

$$\text{Maximum modules per string in series} = 21$$

$$\text{Minimum modules per string in series} = \frac{\text{Minimum input DC voltage to MPPT}}{\text{Rated voltage of module}}$$

$$\text{Minimum modules per string in series} = \frac{500}{31.8}$$

$$\text{Minimum modules per string in series} = 16$$

Table (3.27) Inverter String for Al-sakra primary school .

MPPT	String number1	String number2	VMPPT (V)	Idc (A)	Idc (A)cells in three-string parallel
Inverter 6MPPT/ 2 String					
MPPT (1)	19 cell series	19 cell Series	19×38.1(Voc)=723.9 V	18.39A	18.39×2=36.78A
MPPT (2)	19 cell series	19 cell series	19×38.1(Voc)=723.9 V	18.39A	18.39×2=36.78A
MPPT (3)	18 cell series		18×38.1(Voc)=723.9 V	18.39A	18.39×1=18.39A
MPPT (4)	17 cell series		17×38.1(Voc)=723.9 V	18.39A	18.39×1=18.39A
Number of the cells = (4 ×19) +18 + 17 = 111 cell					

The figures (3.19) and (3.20) show the distribution of photovoltaic panels on the roof of Al-sakra primary school

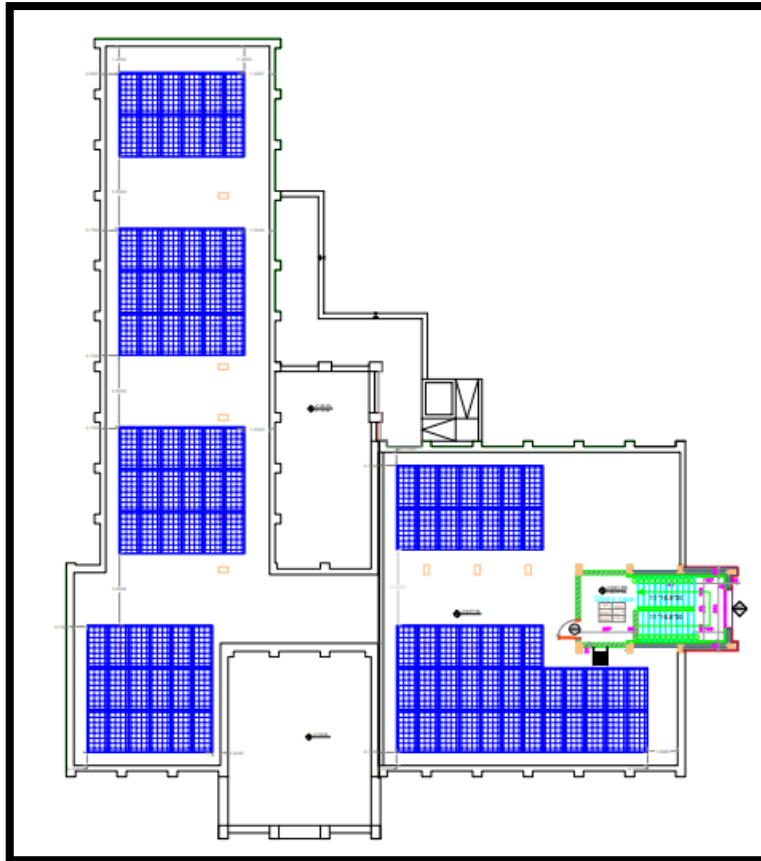

Fig.(3.19) distribution of photovoltaic panels on the roof of a Al-sakra primary school .

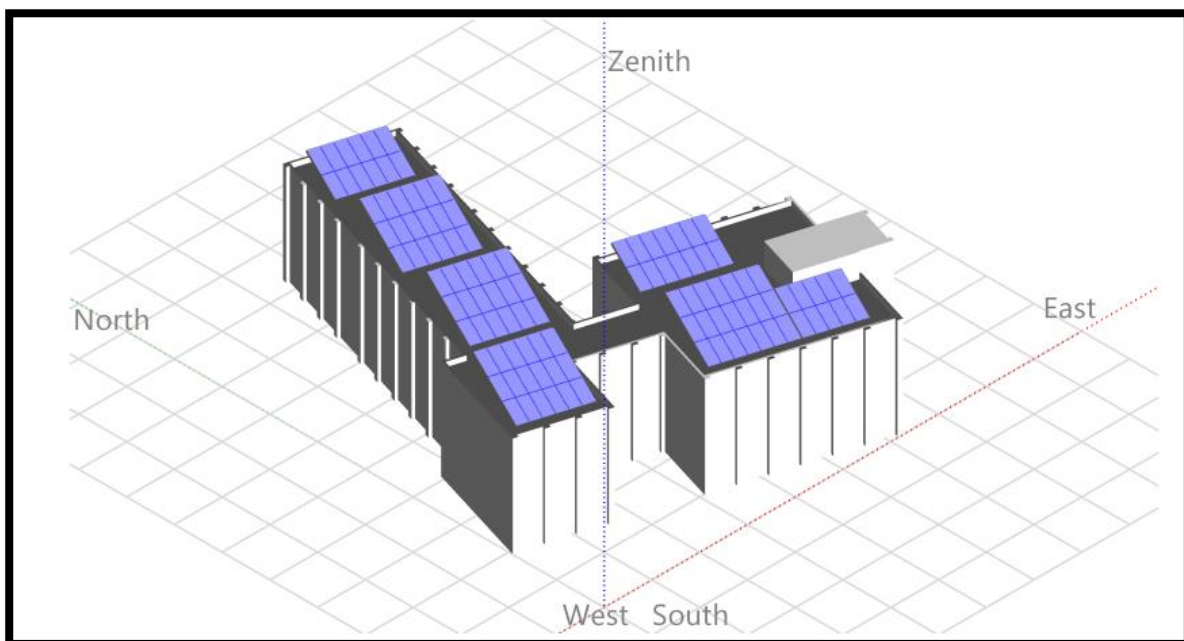

Fig.(3.20) Perspective of the PV-field and surrounding shading scene on the roof of a Al-sakra primary school.

F) Energy output and Calculate revenues and payback period for the project.

The energy produced annually is (theoretically) Using the PVsyst software on a Beit Fajjar Secondary Girls School roof as shown in the table (3.28) and Fig.(3.21).

Table (3.28) Monthly AC Production for Al-sakra primary school .

Month	Monthly AC Production(Kwh)
Jan	6258
Feb	6625
Mar	8669
Apr	9386
May	10296
Jun	10843
Jul	10289
Aug	9943
Sep	8865
Oct	7632
Nov	6235
Dec	5655
Annually	100696

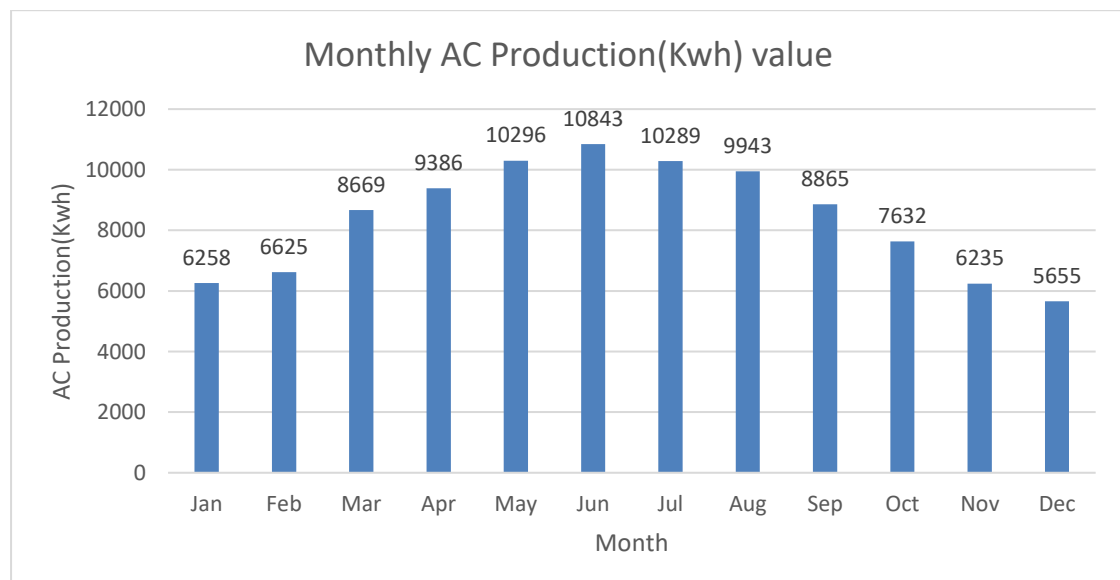

Fig.(3.21) Monthly AC Production for Al-sakra primary school .

Observations of the monthly output of the system on the roof of the school, and the monthly consumption amount of electricity can be shown in the figure (3.22).

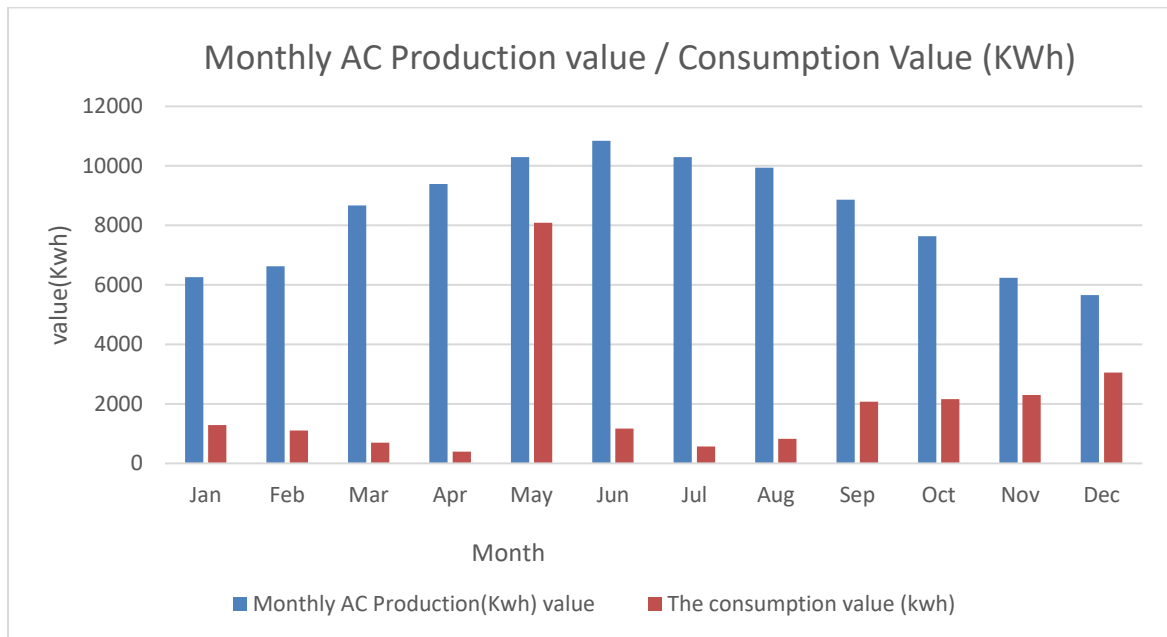

Fig.(3.22) Monthly AC Production / Consumption Value (KWh)for Al-sakra primary school .

From the results shown in Figure (3.14) it was found that the difference between consumption and production is large and this is due to the absence of energy-consuming electrical systems in Palestinian schools, such as heating and cooling systems, as the weather in Palestine in the spring, summer and autumn seasons does not need cooling systems in schools as the weather is moderate.

The Table (3.29) and Figure (3.23) show the AC surplus value (KWh), which is calculated by subtracting the monthly consumption value from the monthly production value

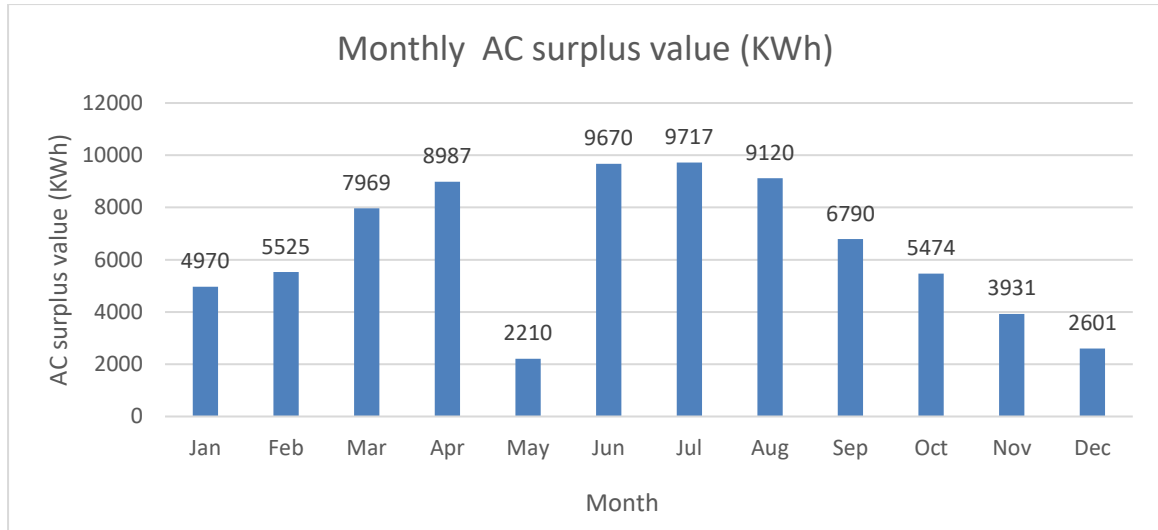

Fig.(3.23) Monthly The AC surplus value (KWh)for Al-sakra primary school.

Table (3.29) Monthly The AC surplus value (KWh)for Al-sakra primary school

Month	The AC surplus value (KWh)
Jan	4970
Feb	5525
Mar	7969
Apr	8987
May	2210
Jun	9670
Jul	9717
Aug	9120
Sep	6790
Oct	5474
Nov	3931
Dec	2601
Annually	76964

By subtracting the consumed value from the produced value, 76964 KWh will be the AC surplus value for 12 months.

Calculating the revenues from selling surplus energy annually.

It is possible to calculate the selling price of energy surplus to the school’s annual need, which is considered the project’s annual profits. It is known that the price of a kilowatt hour (1 Kwh) is sold at a price 0.16 USD approximately equivalent to 0.56 NIS.

Annual revenue = The AC surplus value (KWh) × price of a kilowatt hour (1 Kwh)

$$\text{Annual revenue} = 76964 \times 0.56$$

Annual revenue = 43099.84 NIS

Project cost calculation.

Knowing the costs of establishing the project depends on several factors, including the size of the project and the types of materials and solar panels used in the project.

The total cost of the project = cell capacity × number of cells × Kilowatt price in NIS

$$\text{The total cost of the project} = 0.55 \times 111 \times 4200$$

The total cost of the project = 256410 NIS

Total income over 20 years and Payback period.

If the expected life of the project is 20 years, the project will achieve revenues of up to 861996.8 NIS , as shown in the Figure (3.24) .

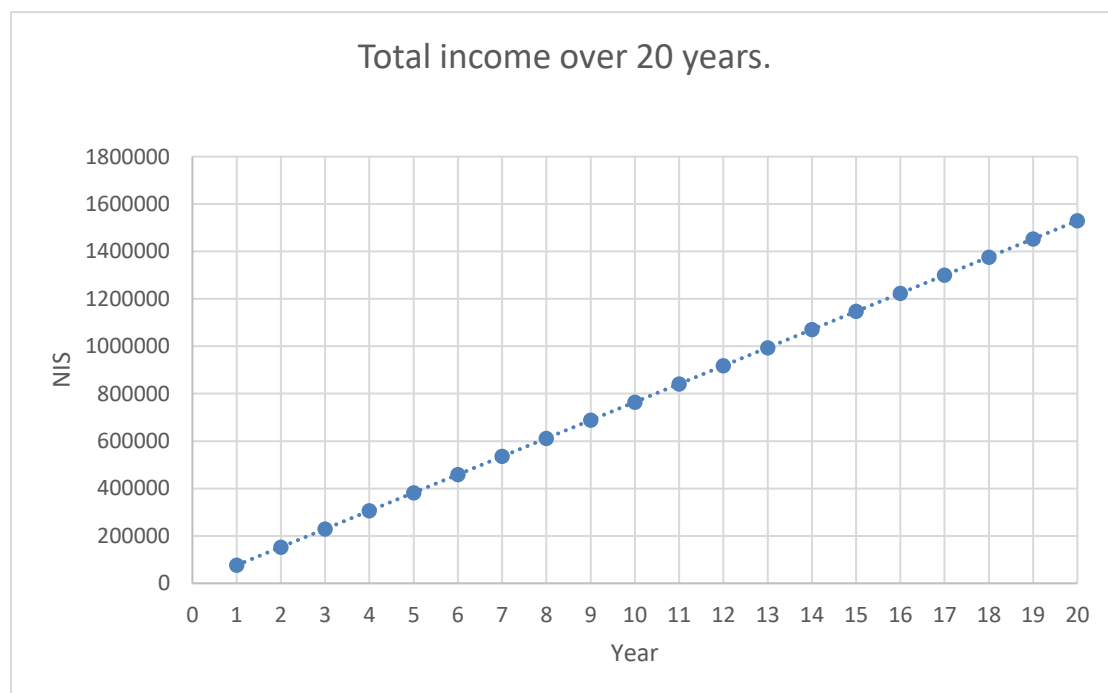

Fig.(3.24) Total income over 20 years for Al-sakra primary school .

Now the project's payback can be determined by knowing the project cost and the project's annual income.

$$\text{Payback period} = \frac{\text{Total income over 20 years}}{\text{The total cost of the project}}$$

$$\text{Payback period} = \frac{861996.8}{256410}$$

$$\text{Payback period} = 3.36 \text{ year}$$

G) Conclusion

Al-sakra primary school is a large space school, it has an available area for the PV panels of 290 m² of the total area 616 m². The calculation shows that it's roof could handle a PV system of 61.05 KW, about 111 PV panels. And this will produce annually 76964 KWh of surplus electricity, were the total annual consumption is 23732 KWh. That means annually income will be 43099.84 NIS and the total cost of the system about 256410 NIS. After making calculations the payback period will be 3.36 years, and the school will produce a total income after 20 years which is the life span of the system about 861996.8 NIS.

Chapter Four

Conclusions and Future work

4.1 Conclusions

The main objective of this study is to demonstrate the effectiveness of exploiting the rooftops of buildings in Palestine to secure energy needs by building and designing photovoltaic systems on these rooftops, because this area of building rooftops constitutes a good area for exploitation in light of the presence of many challenges and obstacles facing the design of solar energy systems. The most prominent of which is the small amount of space available to be used in designing photovoltaic systems. This is due to the occupation policies represented by many procedures and harassments that limit the exploitation of space in designing systems. An example of this is its control over Area C, which constitutes a large area in the West Bank.

In addition to the Area factor, there are many factors that increase the importance of designing solar energy systems in Palestine in general, such as the high electricity bill as a result of high fuel prices, and the frequent electricity cuts implemented by the Israeli Electricity Company, which leads to electricity outages in the West Bank and Gaza Strip. Also, the Gaza Strip in particular has been suffering from major electricity outages for years as a result of the siege imposed on it. All of these factors and others push towards the need to think carefully about exploiting the rooftop areas of buildings to generate electrical energy, which leads to a kind of stability in the field of electrical energy.

In this study, the design of photovoltaic systems on the roofs of three public schools was studied, differing in area, consumption, and size of the photovoltaic system designed for each school, in order to demonstrate the importance, benefit, and effectiveness of building and designing photovoltaic systems on the roofs of buildings, and the construction of systems on the roofs of schools was studied because school roofs are not It is exploited and not fully utilized, thus forming an area that can be used in building and designing photovoltaic systems. Moreover, the amount of electricity consumption in schools is not large because schools do not use systems that consume large amounts of electricity, and also the school closes its doors for approximately 180 days. During the year, there is no high consumption of electricity, and with the presence of photovoltaic systems on its roofs, it will constitute a large source of electrical energy.

In this study, three schools were chosen located in the town of Beit Fajjar, in the south of Bethlehem Governorate, and the photovoltaic system was built for each of the schools' rooftops on the largest possible area of the school's rooftop, taking into account the factors affecting the photovoltaic system, such as the location of the schools, the presence of shadows, the nature of the roofs, and the orientation of the schools. The south and other factors. The design was also made in accordance with the regulations and laws in force in Palestine in terms of system loads, public safety conditions, and Palestinian civil defense laws.

PVsys software was used in the process of building the systems according to the data of the systems, their area and location. The amount of energy produced by these projects during the year was found and the output during each month was known. The number and types of each of the solar panels and inverters used in the projects and how they were distributed over the available space were then compared. The potential energy output with the monthly and annual consumption of schools according to the amount of consumption obtained from the Jerusalem Electricity Company, after which the percentage of surplus energy was calculated and its selling price and payback period were calculated for the three projects.

To sum up Table(4.1) shows a summary of the results for each of the three systems.

Table (4.1) summary of the results for each of the three systems

school	Al-Tahrir Boys School	Beit Fajjar Secondary Girls School	Al-sakra primary school
System area (m ²)	193	418	290
System capacity(kw)	40.7	88	61.05
Number of panels	74	160	111
Annual consumption(Kwh)	12841	9455	17105
Annual production(Kwh)	67995	145990	100696
Annually surplus(Kwh)	55154	136535	76964
Annual revenue(income)	30886.24	76459.6	43099.84
The total cost of the project(NIS)	170940	369600	256410
Total income over 20 years(NIS)	617724.8	1529192	861996.8
Payback period(year)	3.61	4.13	3.36

The three photovoltaic systems proved highly effective in performance and great economic returns. The total area used in the three projects combined was about 901 m², the total number of panels used was 345 panels, and the capacity of the three systems 189.75 Kw, so the annual production 314681 kwh. From the electricity company's readings, it was found that the three schools. It consumes an amount of electricity amounting to 39401 kwh, the annual surplus amount from the three schools is about 268653 kwh, and its annual selling price reaches 150445.68 NIS.

By knowing the output from each project after the expected life of each of the three projects after 20 years and comparing that to the total cost of the project, we notice that the payback period was good, ranging between 3.36 year and 4.13 year.

The results reached from these three systems encourage the importance of implementing solar energy projects in Palestine and exploiting rooftops in the process of designing and implementing photovoltaic systems on rooftops.

As was explained, the amount of electricity and financial income produced by the projects of these three schools was large, so the process of exploiting roofs must take place, for example school roofs in particular, because there are more than 3000 schools in the West Bank and Gaza Strip.

The number of schools in Palestine 3075 When this project is implemented on the roofs of these schools, they will produce 322.54 Gwh, which represents 4.98% of the annual consumption of electricity in Palestine, in addition to the schools' energy consumption, which represents 0.6% of the annual consumption. The total cost of the project will reach 816 million NIS with a payback period of about 5 years, and the total annual income from selling the surplus electricity for schools will be 154 million NIS. This will help reduce the bill for purchasing electricity from Israel, as it will save the Palestinian treasury an amount of 150. 5 million NIS after about 5 years.

4.2 Future work

This study, through analyzing the photovoltaic systems on the roofs of the three schools and demonstrating the effectiveness of these projects, shows the importance of disseminating the idea of creating and designing rooftop systems in general in Palestine, and that the high and distinctive productivity of these projects in Palestine increases the importance of these projects.

Specialists in the fields of energy and planning in Palestine must work to increase studies that emphasize the importance of establishing solar energy projects in Palestine on rooftops, as there are many buildings, whether public or private, in which the roof is not exploited. By conducting in-depth studies in energy and planning, it may become an idea. Establishing energy projects on rooftops is important and widespread.

Economic studies must also be conducted on these projects in order to attract the attention of both the government and the private sector to invest in this vital and important sector, which represents an essential part of people's lives and the continuity of providing services, etc. The electricity sector is of great importance and must be taken care of by developing it and solving all the problems it faces. While researchers focus on conducting studies centered on the subject of photovoltaic systems on the roofs of buildings.

The work on these projects, which concern the energy sector, is constantly developing in all its fields due to the great importance that emerges from these studies. It became clear from this study the importance of exploiting the roofs of buildings in general and the roofs of schools to generate electricity and the economic feasibility of these projects, as they would be if applied to all schools in Palestine. There will be a production of 5% of public consumption in Palestine.

In the end, a number of recommendations must be presented, which came after the implementation of these three projects, explaining their importance.

1. Specialists and researchers in the fields of renewable energy and planning should work to conduct studies showing the importance of establishing photovoltaic projects on the roofs of buildings as an alternative source of energy, and circulate these studies and research to responsible and governmental agencies as well as the private sector.

2. The government must enact laws, regulations and legislation that encourage the exploitation of building rooftops in Palestine and the establishment of photovoltaic systems projects by encouraging the private sector and electricity companies to invest in these projects.

3. Urge and encourage people to move towards solar energy projects because they reduce pollution and the use of fossil fuels, which increase environmental risks and

pollutants, through raising awareness of the importance of renewable energy in schools, universities, and various means of communication.

4. Taking into account good and thoughtful planning of the sites where solar energy projects are planned to be established before the implementation process in order to obtain effective and high-quality photovoltaic systems.

References

- [1] P. Kishore and J. Kisiel, "Exploring High School Students' Perceptions of Solar Energy and Solar Cells," *International Journal of Environmental and Science Education*, vol. 8, no. 3, pp. 521-534, 2013.
- [2] A. Murat and F. Salmanoglu, "A Project That Provides Electricity from Solar Energy for Vocational School Campus," Ali Murat, 2017.
- [3] Q. Hernandez-Escobedo and A. Ramirez-Jimenez, "Sustainable Solar Energy in Mexican Universities. Case Study: The National School of Higher Studies Juriquilla (UNAM)," *Sustainability*, vol. 12, no. 8, p. 3123, 2020.
- [4] M. Ismail, M. Moghannemi and T. Mahila, (2013) Analysis and evaluation of various aspects of solar radiation in the Palestinian territories, *Energy Conversion and Management*, 73, 57-68.
- [5] M. Abu-Hafeetha. Planning for Solar Energy as an Energy Option in Palestine. 2009.
- [6] M. Ouda. Prospects of Renewable Energy in Gaza Strip. Energy Research Development Center, Islamic University of Gaza, Palestine, 2003.
- [7] I. H. Ibrik and M. M. Mahmoud, "Energy efficiency improvement procedures and audit results of electrical, thermal and solar applications in Palestine," *Energy Policy*, vol. 33, no. 5, pp. 651--658, 2005.
- [8] A. Juaidi and F. Montoya, "An overview of renewable energy potential in Palestine," *Renewable and Sustainable Energy Reviews*, vol. 65, pp. 943-960, 2016.
- [9] PCBS, "Energy consumption by sector, energy form and year between 2014 and 2018," Palestinian Central Bureau of Statistics, 2020. [Online]. Available: http://www.pcbs.gov.ps/Portals/_Rainbow/Documents/Schools_ar.html.
- [10] PCBS, "Distribution of schools in Palestine by region and governorate, for the academic years 2014/2015 – 2019/2020," Palestinian Central Bureau of Statistics, June 2020. [Online]. Available: http://www.pcbs.gov.ps/Portals/_Rainbow/Documents/Energy-consum-2014-2018.html.
- [11] M.O.E, "Facts and Numbers," Palestinian Ministry of Education, 2019. [Online]. Available: <http://www.moehe.gov.ps/moehe/factsandfigures>.
- [12] M. Ismail, M. Moghannemi and T. Mahila, "Analysis and evaluation of various aspects of solar radiation in the Palestinian territories," *Energy Conversion and Management*, vol. 73, pp. 57--68, 2013.

- [13] Z. Alabadla and U. Schlin, "Global Solar Radiation Analysis and Possible Linked to Sunspots Number over Gaza, Palestine," *Materials and Environmental Science*, vol. 10, no. 9, pp. 1503-1511, 2020.
- [14] E. Ajlouni and H. Alsamamra, "A Review of Solar Energy Prospects in Palestine," *American Journal of Modern Energy*, vol. 5, no. 3, pp. 49-62, 2019.
- [15] P.E.R.C, "Renewable energy laws and legislation," Palestinian Electricity Sector Regulatory Council, 2015. [Online]. Available: https://perc.ps/perc/?page_id=85.
- [16] R .Graham. *Solar Energy*, Wayland, England, 1990.
- [17] P.Tabb . *Solar Energy Planning: A Guide to Residential Settlement*, McGraw-Hill, New York, 1984.
- [18] S. Ismail, M. Moghavvemi, and T. Mahlia. Analysis and evaluation of various aspects of solar radiation in the Palestinian territories. *Energy Conversion and Management*, 2013. 73: p. 57-68
- [19] Gostein, M., B. Stueve, K. Passow, and A. Panchula. Evaluating a model to estimate GHI, DNI, & DHI from POA irradiance. in 2016 IEEE 43rd Photovoltaic Specialists Conference (PVSC). 2016. IEEE.
- [20] Masters, G. M., *Renewable and efficient electric power systems*. 2013: John Wiley & Sons
- [21] Desideri, U. and P. E. Campana, *Analysis and comparison between a concentrating solar and a photovoltaic power plant*. 2014. 113: p. 422-433.
- [22] Dr. Ayman Rabi, D. I. G., *Solar Energy Production in Palestine // Pre Master Plan*. Palestinian Environmental NGOs Network –Friends of Earth– Palestine (PENGON-FoE Palestine), 2016
- [23] Marcel ŠŮRI, N. Š., Juraj BETÁK, Tomáš CEBECAUER, Artur SKOCZEK, Branislav SCHNIERER, Veronika MADLEŇÁKOVÁ, Ivona FERECOVÁ, *SOLAR RESOURCE POTENTIAL MAPPING: COUNTRY STUDY OF THE STATE OF PALESTINE*. GIS Osrtava 2015, 2015: p. 26-
- [24] SOLARGIS. *Solar GIS*. [Web Info]; Available from: <https://solargis.com/>.
- [25] Alaydi, J. Y., *The solar Energy potential of gaza strip*. 2011. 11 (7-J)
- [26] Alsamamra, H., *Statistical approach for modeling of daily global solar radiation on horizontal surfaces over Hebron city, Palestine*. 2013. 2 (1): p. 60-66.
- [27] Qasrawi, I. and M. Awad, *Prediction of the power output of solar cells using neural networks: solar cells energy sector in Palestine*. 2015. 9 (6): p. 280.

- [28] Hussein, M. and S. Albarqouni, Developing empirical models for estimating global solar radiation in Gaza Strip, Palestine. 2010.
- [29] Juaidi, A., F. Montoya, I. Ibrik, and F. Manzano-Agugliaro, An overview of renewable energy potential in Palestine. 2016. 65: p. 943-960.
- [30] Alaydi, J. Y., The solar Energy potential of gaza strip. 2011. 11 (7-J).
- [31] Nordmann, T. and L. Clavadetscher. Understanding temperature effects on PV system performance. in 3rd World Conference on Photovoltaic Energy Conversion, 2003. Proceedings of. 2003. IEEE.
- [32] Touati, F. A., M. A. Al-Hitmi, and H. J. Bouchech, Study of the effects of dust, relative humidity, and temperature on solar PV performance in Doha: comparison between monocrystalline and amorphous PVS. *International journal of green energy*, 2013. 10 (7): p. 680-689.
- [33] Hasan, A., Thermosyphon solar water heaters: effect of storage tank volume and configuration on efficiency. *Energy conversion management*, 1997. 38 (9): p. 847-854.
- [34] A.Allouhi, Y.El Fouih ,T.Kousksou A.Jamil, Y.Zeraouli, and Y.Mourada . (2015) "Energy consumption and efficiency in buildings: current status and future trends" . *Journal of Cleaner Production* , 109 , 118-130 .
- [35] H. Alsamamra, J. Shoqeir. " Solar Photovoltaic Systems on Public Schools Buildings: A Case Study in Palestine". *American Journal of Electrical Power and Energy Systems*. Vol. 10, No. 1, 2021, pp. 1-5.
- [36] Imad H. Ibrik | (2020) Techno-economic assessment of on-grid solar PV system in Palestine, *Cogent Engineering*, 7:1, 1727131.
- [37] I. Ibrik and F. Hashaika . Techno-Economic Impact of Grid-Connected Rooftop Solar Photovoltaic System for Schools in Palestine: A Case Study of Three School", *International Journal of Energy Economics and Policy*, 2019, 9(3), 291-300
- [38] W. Feng and Z. M. Slameh , " Off-Grid Photovoltaic System Design for Haiti School Project " , *Journal of Power and Energy Engineering* Vol.02 No.11(2014), Article ID:51885,8 pages .
- [39] Alsamamra, H. and Shoqeir J. (2020) Assessment of Wind Power Potential at Eastern-Jerusalem, Palestine. *Open Journal of Energy Efficiency*, 9, 131-149.
- [40] Barbir, F. Veziroğlu, T. and Plass, H. (1990) Environmental damage due to fossil fuels use. *International Journal of Hydrogen Energy*, 15, 739-749.

- [41] Kishore, P. and Kisiel, J. (2013) Exploring High School Students' Perceptions of Solar Energy and Solar Cells. *International Journal of Environmental and Science Education*, 8, 521-534.
- [42] Jamil, M. Kirmani, S. and Rizwan, M. (2012) Techno-economic feasibility analysis of solar photovoltaic power generation: A review. *Smart Grid Renewable Energy*, 3, 266-275.
- [43] energy informative ,Mathias Aurrel Maehlum 2013 <http://energyinformative.org/grid-tied-grid-and-hybrid-solar-systems>
- [44] Asma M. Yasin "Optimal Operation Strategy and Economic Analysis of Rural Electrification of Atouf Village by Electric Network, Diesel Generator and Photovoltaic System" A thesis presented to the University of An-Najah National University, Nablus, Palestine, 2008
- [45] Leena M. Ammous "Techno-Economic Impact of Using On-Grid and Off-Grid PV Solar Systems in West Bank (Masoud village as a case study) " A thesis presented to the University of An-Najah National University, Nablus, Palestine, 2016
- [46] Prof. Marwan M. Mahmoud, Lecture of renewable energy 1&2.
- [47] Falinirina F. Rakotomanandro "Study of Photovoltaic System" Master thesis presented to the Ohio State University, 2011.

تأمين احتياجات الكهرباء من أنظمة الطاقة الشمسية الكهروضوئية على الأسطح

اعداد: علي يوسف محمد طقاطقة

اشراف: د.حسين السمامرة

ملخص:

يعاني قطاع الطاقة في فلسطين بسبب سياسات الاحتلال الإسرائيلي المختلفة، ويعتبر قطاع الطاقة في فلسطين باهظ الثمن نتيجة اعتماد القطاع الصناعي في فلسطين على الكهرباء بشكل مباشر، لذا لا بد من اللجوء إلى مصادر الطاقة المتجددة كمصدر جديد للطاقة.

تعتبر أنظمة الطاقة الشمسية من أهم مصادر الطاقة المتجددة في العالم، وتسعى دول العالم اليوم إلى استغلال هذا الأسلوب في تأمين احتياجاتها من الطاقة. لاستغلال الطاقة الشمسية يجب توافر المساحات التي يجب أن توضع عليها مشاريع الطاقة الشمسية، ومن هنا جاءت فكرة هذه الدراسة في استغلال أسطح المدارس شبه الفارغة في توليد الكهرباء من خلال مشاريع الطاقة الشمسية الكهروضوئية، لأن المدارس تغلق أبوابها حوالي 180 يوماً سنة، ولها مدة عمل يومية بحد أقصى 7 ساعات، فضلاً عن انخفاض استهلاك الطاقة، كل ذلك يحفز استغلال هذه المساحات المتوفرة على أسطح المدارس لتوليد الطاقة الشمسية.

من أجل دراسة جدوى استغلال أسطح المباني لتوليد الطاقة الكهربائية، تم في هذه الدراسة استخدام برنامج PVsyst لبناء وتصميم ثلاثة أنظمة كهروضوئية على أسطح ثلاث مدارس مختلفة المساحة وكمية الاستهلاك، ومن ثم حساب فترة الدخل والاسترداد. وبلغت المساحة الإجمالية المستخدمة في المشاريع الثلاثة مجتمعة حوالي 901 م²، وبلغ إجمالي عدد الألواح المستخدمة 345 لوح، وقدرة الأنظمة الثلاثة 189.75 كيلو واط، فيبلغ الإنتاج السنوي 314681 كيلو واط ساعة. ومن قراءات شركة الكهرباء تبين أن المدارس الثلاث تستهلك كمية من الكهرباء تبلغ 39401 كيلو واط ساعة، وبذلك يبلغ الفائض السنوي من المدارس الثلاث حوالي 268653 كيلو واط ساعة، ويصل سعر بيعها السنوي إلى 150445.68 شيكل.

عدد المدارس في فلسطين 3075 عندما يتم تنفيذ هذا المشروع على أسطح هذه المدارس ستننتج 322.54 جيغا واط ساعة، وهو ما يمثل 4.98% من استهلاك الكهرباء السنوي في فلسطين، بالإضافة إلى استهلاك المدارس من الطاقة والذي يمثل 0.6% من الاستهلاك السنوي. وستبلغ التكلفة الإجمالية للمشروع 816 مليون شيكل مع فترة استرداد حوالي 5 سنوات، وسيكون إجمالي الدخل السنوي من بيع فائض الكهرباء للمدارس 154 مليون شيكل. وسيساعد ذلك في تقليل فاتورة شراء الكهرباء من إسرائيل، كما سيوفر على الخزينة الفلسطينية مبلغ 150.5 مليون شيكل بعد حوالي 5 سنوات.