

**Deanship of Graduate Studies
Al-Quds University**

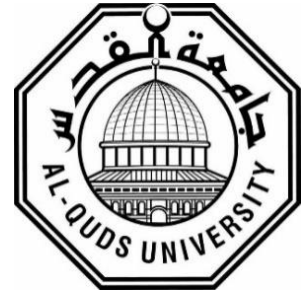

**The Efficiency of solar Photovoltaic projects on school
roof-tops in Palestine: a case study in Bani Naeem town**

Ayat Issa Ahmad Zedat

M.Sc. Thesis

Jerusalem – Palestine

1446/2025

The Efficiency of solar Photovoltaic projects on school roof-tops in Palestine: a case study in Bani Naeem town

Prepared By: Ayat Issa Ahmad Zedat

B.Sc.: Palestine Polytechnic University, Palestine

Supervisor: Dr. Husain Alsamamra
Physics Department, Al-Quds University, Palestine

A Thesis Submitted in Partial fulfillment of requirements for the degree of Master of Science from the Department of Physics, Faculty of Science and Technology, Al-Quds University.

1446/2025

Al-Quds University
Deanship of Graduate Studies
Physics Department

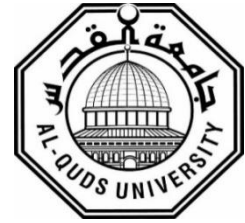

Thesis Approval

**The Efficiency of solar Photovoltaic projects on school roof-tops in
Palestine: a case study in Bani Naeem town**

Prepared By: Ayat Issa Ahmad Zedat



Registration No: 22020057

Supervisor:

**Dr. Husain Alsamamra, Physics Department, Al-Quds University,
Palestine.**

Master thesis submitted and accepted, Date: 26-04-2025

The names and signatures of the examining committee members are as follows:

- | | |
|--|--|
| 1- Head of Committee: Dr. Husain Alsamamra | Signature:  |
| 2- Internal Examiner: Prof. Musa Abutier | Signature:  |
| 3- External Examiner: Dr. Karam Awawdeh | Signature:  |

Jerusalem – Palestine
1446/2025

Dedication

To my husband and support

To the brightness of my life, Younis, Youssef, and Karim, my kids.

To my father, to my beloved mother, to my brothers and sisters.

And to my friends.

Declaration

I certify that this thesis submitted for the degree of the master is the result of my research, except where otherwise acknowledged, and that this thesis, neither in whole nor in part, has been previously submitted for any degree to any other university or institution.

Signed:

A handwritten signature in black ink, reading "Ayat Issa Ahmad Zedat", written over a horizontal line.

Ayat Issa Ahmad Zedat

Date: 26-04-2025

Acknowledgments

Above all, I am thankful to Allah for providing me with the bravery, determination, and guidance I required to do this study. For his significant assistance, encouragement, and advice during this project, I would like to sincerely thank my supervisor, Dr. Husain Alsamamra. Also I want to express my gratitude to everyone who has helped and encouraged me during this study process.

Abstract

Given the difficulties and barriers that nations face in the energy sector, as well as population growth and rising energy consumption, it is now necessary to turn to alternative energy sources, especially renewable energy sources, which are essential for meeting global demands and ensuring environmental sustainability because of their sustainability and availability.

The energy situation in Palestine in particular is related to infrastructural and political and economic limitations, which demand for considerable work to resolve. It is now imperative to find a fossil fuel substitute, and solar energy has turned out to be the best option. In Palestine, it is a viable choice for enhancing sustainability and energy security.

Appropriate locations for solar energy projects must be accessible in order to capture solar energy. Using the almost empty rooftops of schools to produce power through photovoltaic solar energy projects is where the concept for this study developed. Along with reduced energy use, schools close for around 180 days of the year and operate no more than seven hours a day. This promotes the use of these open areas on school roofs for solar energy production.

To conduct a feasibility assessment of using building rooftops for solar energy generation, this study utilized a photovoltaic solar energy software PV_{sys} to create a virtual photovoltaic system on the rooftop of Bani Naim Secondary School for Girls. The system's capacity was estimated at 104 kW, with a total area of 494 m², using 189 panels, and an expected annual production of 176,098 kWh. According to the regional electricity company, the school's consumption was 9,510 kWh, resulting in an annual surplus of 166,588 kWh, and the selling price each year reached 96621.04 NIS. There are over 3,075 schools in Palestine. The project will generate 541Gwh when it is implemented in these schools, and it will cost around 920 million NIS over a period of six years for recovery.

Table of Contents

Declaration:	I
Acknowledgments	II
Abstract	III
Table of contents	IV
List of Tables	VI
List of Figures	VII
List of abbreviations	VIII
Chapter 1 Introduction	1
1.1 Background to the Study.....	1
1.2 Study Objectives	2
1.3 Literature Review	2
1.4 Energy status in Palestine	4
1.5 Justifications.....	7
1.6 Problem statement.....	7
Chapter 2 Theoretical framework	8
2.1 The physical background of solar cells.....	8
2.2 photovoltaic systems.....	9
2.2.1 The off-grid solar power system	9
2.2.2 Grid-connected system	10
2.2.3 Comparison of off-grid and grid-connected solar systems	10
2.2.4 Photovoltaic system components	11
2.3 techno-economic assessment of PV systems	11
Chapter 3 Methodology	13
3.1 Study area.....	13
3.2 Bani Naeem location.....	14
3.3 The selected school data	15
3.4 Weather Data	15
3.5 Working phases and computer tools	16
Chapter 4 Results and Discussion	18
4.1 Introduction	18
4.2 PV systems and revenues	18
4.2.1 Electricity consumption	18
4.2.2 Specifications of Bani Na'im Secondary School for Girls.....	19

4.2.3 Values of Monthly Global Solar Radiation in Bani Naim	19
4.2.4 PV systems and revenues	20
Chapter 5 Conclusions and Future Work.....	26
5.1 Conclusions.....	26
5.2 Future Work	27
References.....	28
ملخص.....	31

List of Table

Table (2.1): Comparison of grid and off-grid connected solar systems.....	10
Table (3.1): School information.....	15
Table (3.2): Weather data displays the regions for 2023.....	16
Table (4.1): Electricity consumption and financial cost for school.....	18
Table (4.2): Specifications of Bani Na'im Secondary School for Girls	19
Table (4.3): Monthly global solar insolation at Bani Naim	19
Table (4.4): information entered into PVsyst software for Bani Naim Secondary School.....	20
Table (4.5): The photovoltaic solar module specifications for Bani Naim Secondary School for Girls.....	21
Table (4.6): Characteristics of the Inverter for Bani Naim Secondary School for Girls.....	21
Table (4.7): Inverter String for Bani Naim Secondary School for Girls.....	22
Table (4.8): Monthly AC Production for Bani Naim Secondary School for Girls	23
Table (4.9): Monthly AC surplus value (KWh)for Bani Naim Secondary School for Girls....	24
Table(4.10): summary of the results.....	27

List of Figures

Figure No.	Description	Page
Figure1.1	Current situation of the energy framework in Palestine.	5
Figure1.2	Electricity demand in Palestine.	6
Figure2.1	Schematic of a simple single-junction back contact solar cell structure.	9
Figure2.2	Block diagram for the stand-alone PV system.	9
Figure2.3	Configuration for Grid-connected system.	10
Figure3.1	Map of West Bank and Gaza.	14
Figure3.2	Map of Bani Naeem.	14
Figure3.3	Bani Na'im Secondary Girls' School.	15
Figure3.4	displays the region's weather data for 2023.	16
Figure4.1	Electricity consumption and financial cost (kWh and NIS) for Bani Naeem Secondary Girls' School.	19
Figure4.2	Solar insolation (KWh/m ² .day) in Bani Naeem.	20
Figure4.3	distribution of photovoltaic panels on the roof of Bani Naeem Secondary School for Girls.	22
Figure4.4	shows a perspective of the Bani Naeem Secondary School for Girls.roof, including the PV field and surrounding shading.	22
Figure4.5	Monthly AC Production for Bani Naim Secondary School for Girls.	23
Figure4.6	Monthly AC Production / Consumption Value (KWh) Bani Naim Secondary School for Girls.	24
Figure4.7	Monthly AC surplus value (KWh)for Bani Naeem Secondary School for Girls.	25
Figure4.8	Total income over 20 years Bani Naeem Secondary School for Girls.	25

List of Abbreviations

Abbreviation	Meaning
PCBS	Palestinian Central Bureau of Statistics.
PENRA	Palestinian Energy & Natural Resources Authority
USD	United States dollar.
NIS	New Israeli shekel.
PV	photovoltaic
PVsyst	photovoltaic system
AC	Alternative Current.
DC	Direct Current.
Kwh	Kilo Watt hour.
Gwh	Giga Watt hour.
MPPT	Maximum Power Point Tracking.
Vdc	Volts direct current.
Iac	Maximum AC Output current.
p _{max}	Maximum power
I _{sc}	Short Circuit Current
V _{oc}	Open Circuit Voltage
PR	performance ratio
m	meter
mm	Millimeter
m ²	Square meters
kg	Kilogram
A	Ampere
V	Volt
W	Watt

Chapter One

Introduction

1.1 Background to the Study

In light of the global energy challenges and barriers, population growth, and rising energy consumption, alternative energy sources particularly renewable energy sources have become indispensable for attaining environmental sustainability and satisfying global demands due to their sustainability and availability. Recently a lot of work has been done to achieve the highest level of energy self-sufficiency and switch to solar energy (Kishore & Kisiel, 2013).

One of the most important areas where major gains can be made is the use of solar energy in the education sector, where roofs can be exploited. Installing solar energy projects in almost empty schools could have several benefits, including energy saving, reduced electricity costs, better education, educating students about the need of renewable energy, and the creation of new job opportunities. Burning fossil fuels emits carbon dioxide and other greenhouse gases into the atmosphere, making it one of the main contributors of climate change. This illustrates the importance of switching to renewable energy sources, like solar and wind, to reduce the effects of fossil fuels. Renewable energy has served a major role in the development of various international developments in recent years Renewable energy is one of the most important energy sources for generating electricity without using fossil fuels, which also reduces pollution and slows global warming (Ates & Salmanoğlu,2017).

The energy sector in Palestine, in particular, faces numerous challenges because of the political climate. It is totally reliant on imported energy supplies, with 87% coming from Israel, 4% from Jordan and Egypt, and the remaining 9% being produced locally in Gaza Projects utilizing solar energy are regarded as a significant investment in the nation's educational future and a necessary first step toward sustainability. Palestine is ideally situated for the exploitation of solar energy because of its generally mild climate and abundant availability to sunshine, About3000 hours of sunlight are received by the majority of Palestine each year, with average solar radiation levels ranging from 5.4 to 6.0 kWh/m².day (Juaidi et al., 2016) In comparison to other locations throughout the world, such as Madrid, Spain, which has a 4.88 kWh/m².day potential and Sydney, Australia, which has a 4.64 kWh/m².day potential, these statistics demonstrate a respectable potential for extraction feasibility (Alsamamra&Ajlouni,2019) Investing in green energy projects is the best option, and recently, many countries have become more aware of the feasibility of these projects and that they are a good investment in terms of both the environment and the economy. The following was recommended for rooftop PV systems based on some research on photovoltaic energy system analysis. It was assumed that if 10% of Palestinian rooftops had an average area of 150 m², this

would result in an annual energy yield of 146 GWh, which would cover roughly 2.5% of all electricity imports in Palestine (Carvajal-Romo et al., 2019).

A significant step toward attaining environmental sustainability and raising educational standards is the integration of solar energy into Palestinian schools. Due to Palestine's year-round sunshine, solar energy is a perfect way to meet schools' electricity needs while lowering expenses and reducing reliance on an unstable electrical system. (Ouda,2003).

Because schools provide enormous roof surfaces that facilitate the installation of solar panels and renewable energy systems, the Energy and Natural Resources Authority, working together with donors, has initiated a number of photovoltaic energy projects. Furthermore, the difficulties schools encounter in paying for general operating expenses and electricity bills motivate them to step up their efforts to build solar and renewable energy systems the National Initiative project has brought the total number of solar-powered schools to 525 through a net metering method, the initiative will pay the targeted school's electricity bill, lowering the amount owing to the government. In the case of large areas, it will also profit from the surplus (P.E.R.C, 2015).

In summary, this study will investigate the viability of installing solar photovoltaic energy projects on school rooftops and generating electricity for educational purposes. We will provide analysis about the project's cost, energy production, payback period, and surplus that is fed back on to the electrical grid. The project will be carried out virtually at Bani Naim Secondary School for Girls, one of the North Hebron Education Directorate's schools. The school is situated in the town of Bani Naim, seven kilometers east of Hebron.

1.2 Study Objectives

Assessing the viability of installing solar cell projects on the roofs of abandoned schools in order to make use of these areas is the primary goal of this research. The study will concentrate on a rooftop of 900 square meter Bani Naim Secondary School for Girls. This work will provide an analysis and comparison of monthly production and consumption of power, excess energy, payback period, and the size of the photovoltaic solar energy project.

1.3 Literature review

The effectiveness of solar systems installed on residential building roofs has been the subject of numerous research. The findings demonstrate that PV system installation on residential structures might hasten the shift to sustainable energy and renewable energy. Building types with two to four residential units can produce more power than they are expected to need in the future. In 2030, building types with four to eight residential units can generate their own electricity. More than half of their 2030 future consumption can be produced by building types with 12–24 residential units (Tayeh et al., 2021).

The design of photovoltaic solar energy systems is significantly influenced by the shape of the roof Depending on the local conditions, either integrated solar cells or integrated solar cells and solar materials should be used. Ongoing research and development of solar cell materials, with a focus on application, has produced very successful methods to enhance solar cells on surfaces, such as increasing cell efficiency, reducing production costs, improving building integration, and providing flexibility in positioning them on uneven building roofs.

Together with new technology, government regulations are being implemented to help meet carbon peak and high productivity goals.

Calculating the potential capacity for energy output in rooftop solar power producing systems requires taking into account the quality of the incident light spectrum (Yao & Zhou, 2023).

A study used a variety of artificial intelligence techniques to verify and compare maximum power point tracking (MPPT) in photovoltaic (PV) systems. The study demonstrated the efficacy of each MPPT technique and contrasted it with other AI techniques (Kermadi& Berkouk,2017).

In one study, the PV Planner program was used to evaluate the operation of a grid-connected photovoltaic solar power system at an Algerian school (a-Si) technology was the one with the highest energy efficiency and performance ratio after four different module technologies were compared. The impact of energy distribution management programs on the power system was also examined in the study. The data showed that the average annual energy efficiency and performance ratio for (a-Si, CdTe, CIS and c-Si) technologies were 16.6 MWh - 77.1%, 18.0 MWh - 83.8%, and 17.5 MWh - 81.1%, respectively. Consequently, amorphous silicon-based photovoltaic cell technology performs better than rival technologies in this domain (Haffaf et al.,2020)

Mohammadi et al. (2018) conducted a study that assessed 5MW grid-connected solar systems in eight selected cities along the southern coast of Iran from a techno-economic standpoint. From an economic perspective, the 1-axis tracking system is the best choice for investment in any city, according to a comparison of fixed tilt, 1-axis, and 2-axis systems (Mohammadi et al., 2018).

Several methods have been put in place by the Malaysian government to lower carbon emissions and preserve the sustainability of the nation's energy resources. Among these is the utilization of renewable energy sources. One of the most promising sources is solar energy due to its abundance and ease of use. In Malaysia, the use of rooftop photovoltaic solar energy systems is rapidly expanding as an alternative energy source due to growing interest and existing regulations. Installing photovoltaic solar power on rooftops is beneficial for educational institutions, as seen by the significant positive savings on energy and electricity bills. Monocrystalline silicon can reduce emissions by about 26,260 tons of carbon dioxide per year. These findings demonstrate that educational facilities may benefit from rooftop photovoltaic solar panels. Decision-makers and educational institution management can also utilize this study as supporting data when putting photovoltaic solar panels into place to meet the country's energy sustainability goals and decarbonize the energy supply (Khairi et al., 2022).

An investigation in 2018 assessed the technical and financial performance of grid-connected solar power plants installed on the roofs of five different climate zones in China. According to the survey, the most cost-effective region is Kunming, which has the lowest net production (\$113,382) and energy cost (\$0.073/kWh). Furthermore, the Kunming region is the most environmentally friendly location for grid-connected solar power generation due to its lowest greenhouse gas emissions (Li et al., 2018).

In order to reduce Palestine's dependency on imported electricity, the viability of utilizing renewable energy, particularly solar energy, to power agricultural pumps for groundwater extraction in the Tulkarm District was examined. The 1,300 m² of solar panels that comprise the proposed system would provide half of the electricity required for the pumps. The system is positioned as a practical and sustainable solution to the region's agricultural energy needs, with a payback period of 2.5 years (Ramadan et al., 2023).

PV systems with a combined capacity of 7.68 kWh installed on the rooftops of three Palestinian schools were the subject of a 12-month scientific study that assessed their technical and financial performance. The results showed that each system produced 10.930 MWh of energy annually on average, and the average performance ratio for the three schools was 78%. In order to promote the installation of PV systems in educational institutions, these findings support the need for more technical and financial analysis study. With a payback period of fewer than five years, the systems demonstrated an internal rate of return (IRR) of about 20%. Solar energy is emphasized in the study as the greatest choice due to its high efficiency and affordability (Ibrik &Hashaika,2019).

In Al-Dhaheriya Secondary School as a case study to examine the feasibility of putting solar energy systems on Palestinian school rooftops. According to the calculations, putting 144 solar panels with a combined capacity of 57.16 kW on the roof may generate 92,866 kWh a year. Installing these systems in all 3,074 of Palestine's schools will result in a 5.12% yearly electricity consumption throughout the nation. The project was expected to pay for itself in 4.38 years, with an additional 43 million USD per year going to the Palestinian Treasury after that (Alsamamra&Shoqeir,2021).

1.4 Energy status in Palestine

Palestine faces significant energy and economic challenges as a result of the political barriers imposed by the Israeli occupation. More over 90% of Palestine's energy imports come from Israel, with a small percentage coming from neighboring countries like Jordan and Egypt. The West Bank was further strained and the situation worsened by the October war. These issues include a general decline in the national economy, rising costs, and greater unemployment.

As the population grows, there will likely be a greater need for energy-intensive enterprises. Given the rising costs of fossil fuels and their negative impacts on the environment and human health, Palestine's best option is to invest in clean, sustainable green energy alternatives (Abualkhair,2007; Hamed et al., 2012).

Similarly, the geographical divisions and administrative control by the occupation over the energy sector and most other sectors make it difficult to establish a unified plan for the energy sector. Not only that, but the Israeli occupation also prevents energy trade with nearby areas, in addition to the high prices in Palestine compared to other regions. Palestinians use the least amount of energy in the Middle East, approximately 0.79 MWh per person at a higher cost compared to other countries. On the other hand, the electricity sector in Palestine suffers from high costs, poor management, and weak infrastructure (Abualkhair,2007; OSLO, 1995).

The major 161 kV transmission lines carried the imported electricity from Israel with a connecting point in the center that regulates how much energy reaches the Palestinian side, these wires are subsequently transformed into 33 kV or 22 kV transmission lines While the Israeli Civil Administration is in charge of political management of this point, the Israeli Electric Company is in charge of technical management.

The Israeli Electric Company owns the lines that run up to the connecting points, while the Palestinian Electric Transmission Company owns the remaining portion of the transmission lines that connect to the low-voltage power generating facility. After the low-voltage station, the power networks are owned by local municipalities or private Palestinian power distribution companies (PENR, 2014). Therefore, the real energy policy model with the actual intitle energy framework is depicted in Figure (1.1).

Furthermore, as the need for energy is growing daily, the best way to take for Palestine is to work toward developing green, renewable energy projects, of which solar energy is one of the most crucial sources. However, for some projects, funds and donors are necessary for a good investment in these initiatives. The sustainable energy situation in Palestine, as well as its effects on the environment and the economy, must also be understood by the public and the government.

Palestinians are encouraged to increase the use of solar energy to generate power as part of their goals since it is accessible, affordable, and has many advantages. To enhance and encourage the use of renewable energy in Palestine, the Palestinian Energy Authority unveiled a renewable energy plan that aims to increase the use of renewable energy to meet 10% of the country's total electricity consumption. To put it another way, it wants to generate 130 megawatts of power.

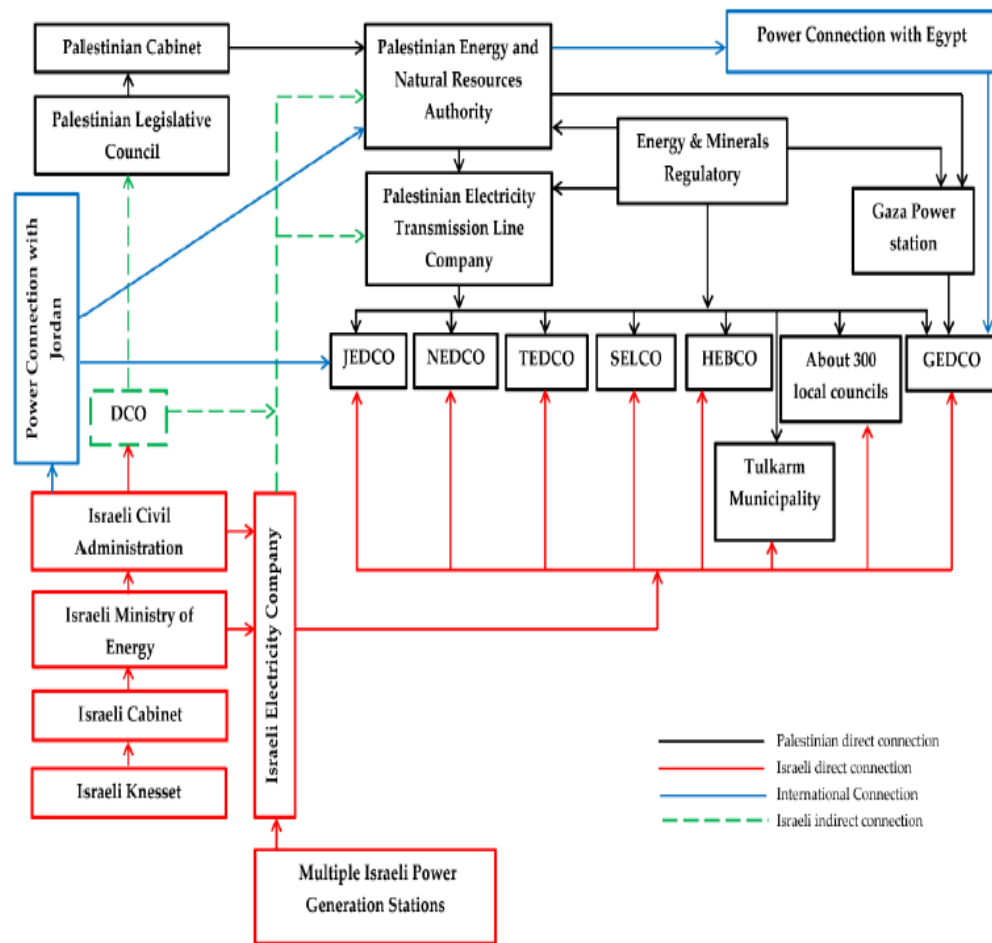

Fig (1.1): Current situation of the energy framework in Palestine (Khatib et al., 2021).

Additionally, in 2015, the Palestinian government announced plans to oversee grid-connected solar systems through net metering regulations (Boero et al., 2016).

The only secure and practical energy source in Palestine is solar energy, which is plentiful, independent of the Israeli Electric Corporation, and has enormous potential. With an annual average radiation of 2285 kWh/m², the Hebron region of Palestine experiences the greatest rate of direct natural radiation from May to September compared to any other month (Omar & Mahmoud, 2018; Rabi & Ghanen, 2016).

Figure (1.2) shows the anticipated peak demand for electrical energy in the West Bank towns in 2029, with Hebron city having the highest predicted demand at 1125,120 MWh (Palestine Investment Fund, 2018).

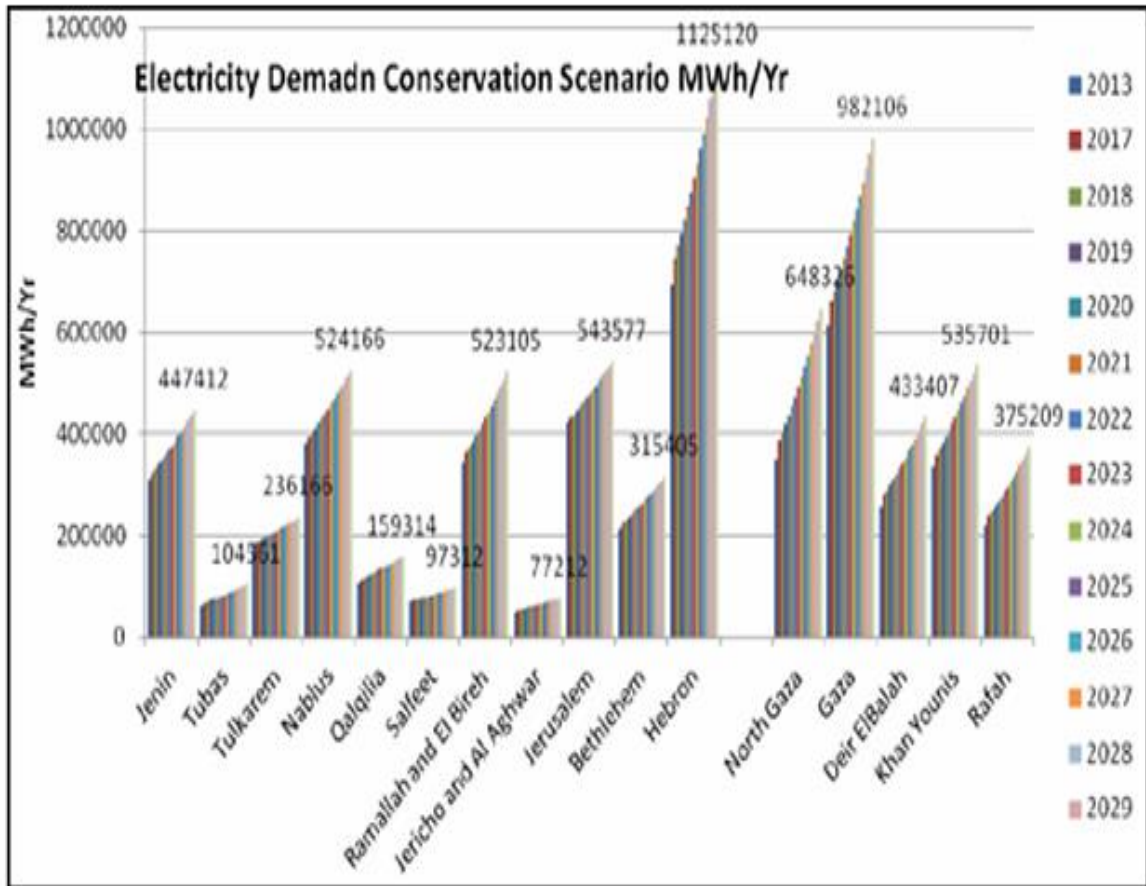

Fig (1.2): Electricity demand in Palestine (Palestine Investment Fund, 2018).

The solar school rooftop project offers several benefits in a variety of industries, and because of its nature, its implementation yields even more advantages that need consideration. Due to the fact that schools are only open five days a week, with one month off for winter and three months off for summer, their electricity usage stimulates investment on all of their rooftops. When we discuss the lowest levels of consumption over the summer, we might discuss zero consumption during these months, which has advantages and generates more energy, zero school expense. Installing solar energy systems on Palestinian school rooftops can save electricity costs, encourage economic growth, and increase energy independence. Additionally, they promote sustainable practices in the classroom and increase public understanding of green energy. This can ease tensions and debt in Palestinian towns and lessen dependency on Israel for energy purchases (Rabi & Ghanen, 2016; Palestine Investment Fund, 2018).

1.5 Justifications

An important barrier to the efficient operation of educational institutions is the dependence on imported electricity and the regular power outages in Palestinian schools. Additionally, schools are financially burdened by the high cost of electricity, which impedes the advancement of instructional procedures.

A practical and effective solution to these issues is the creation of clean energy systems, especially solar energy. The expansion and development of solar energy systems affords long-term returns on investment. Solar energy helps to safeguard the environment by reducing greenhouse gas emissions and the effects of global warming since it is clean and renewable. Furthermore, by promoting interest in science, engineering, and solar energy system maintenance, this initiative provides an excellent opportunity to encourage students to pursue careers in these fields and contribute to the development of competent workers in the renewable energy sector. The school was selected in Bani Naim, a town that benefits from many days of sunshine all year long, particularly in the spring and summer, making it a good location for solar energy projects.

1.6 Problem statement

The reliability and high cost of electricity are substantial obstacles for Palestinian schools, with high electricity bills and frequent power outages being major issues in the education sector. Palestine has a lot of solar radiation, so there is unrealized potential for using solar energy and other renewable energy sources on school rooftops. At Bani Na'im Secondary Girls' School in particular, this study is to assess the viability of installing solar energy systems on school rooftops in order to offer an economical and environmentally friendly energy option. Additionally, the solar energy project will be conducted virtually using PV_{sys} tool. Photovoltaic cell size will be specified, as well as the number of cells and arrays, the inverter type and size will also be specified. The study will analyze and compare the energy produced by the solar system with the school yearly electricity use, maintain educational activities, and save electricity expenses.

Chapter Two:

Theoretical framework

2.1 The physical background of solar cells:

Solar cells are devices that use the photovoltaic effect, in which light photons cause electrons to shift from the valence band, which is a lower energy level, to the conduction band, which is a higher energy level.

The photovoltaic effect in solar panels is the physical principle that underlies the transformation of light energy into electrical energy. This occurrence is clarified by quantum mechanics and entails the interaction between light and materials, especially the semiconductors found in solar cells. When sunlight hits the surface of a solar cell photons (light particles) transmit energy that is proportional to the frequency of the light, as shown by the equation:

$$E = h\nu$$

A p-n semiconductor junction is used in the design of the solar cell to separate the charges on opposite side of the junction, producing an electric current.

Charge carriers (electron-hole pairs) are created by light absorption, separated in the junction, and collected at the junction terminals. These three processes are the essential components of the PV effect. Electrons can recombine with holes at a metal absorber interface because the chemical energy of these carriers is transformed into electric energy (Yoshikawa et al., 2017).

A solar cell is composed of two varieties of semiconductors: p-type and n-type silicon. P-type silicon is created by introducing atoms, such as boron or gallium, which have one fewer electron in their outer shell compared to silicon. This deficiency results in the formation of an electron vacancy, or "hole."

On the other hand, n-type silicon is formed by adding atoms that possess one extra electron in their outer shell, like phosphorus. Phosphorus has five electrons in its outer shell instead of the four found in silicon. While it forms bonds with neighboring silicon atoms, one of its electrons remains unbonded and is free to move within the silicon structure.

A solar cell features a layer of p-type silicon adjacent to a layer of n-type silicon. The n-type layer contains an abundance of electrons, while the p-type layer has a surplus of positively charged holes (vacancies from missing valence electrons). At the interface of these two layers, electrons from the n-type layer migrate into the holes of the p-type layer, resulting in a region around the junction known as the depletion zone, where electrons occupy the holes as shown in figure (2.1).

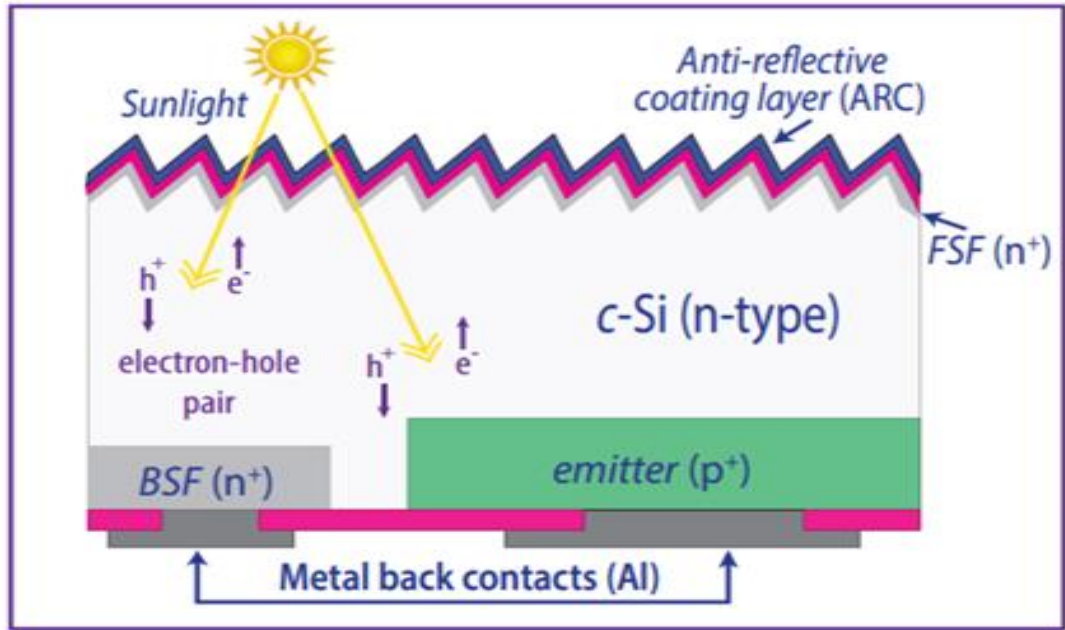

Fig. (2.1): Schematic of a simple single-junction back contact solar cell structure (Luque & Hegedus, 2011).

2.2 photovoltaic systems

A photovoltaic system denotes the whole setup designed to generate electricity and provides it to either the grid or final consumers. There are two primary varieties of grids as the following:

2.2.1 The off-grid solar power system runs on its own and stores the electricity produced by photovoltaic energy in batteries for use at a later time. The off-grid solar power system runs on its own and stores the electricity produced by photovoltaic energy in batteries for use at a later time. Because it does not depend on changing energy prices, this system is perfect for anyone who want total control over their energy source. Additionally, it is ideal for remote locations without connection to the electrical grid. However, the high cost of buying and maintaining the batteries makes this system relatively costly, necessitating a significant project budget (Mane et al., 2022).

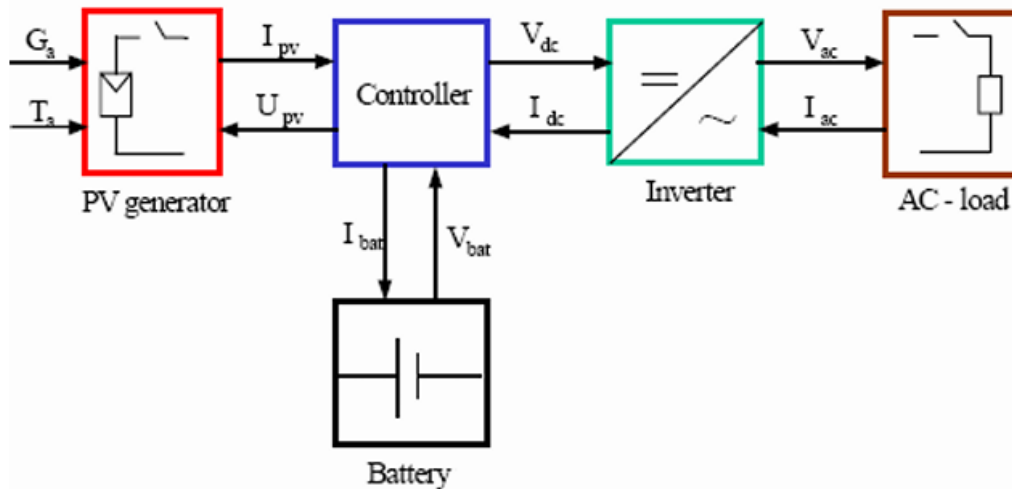

Fig. (2.2): Block diagram for the stand-alone PV system (Alboteanu et al., 2008).

2.2.2 Grid-connected system

Through an inverter, the grid-connected system connects solar panels to the utility grid, enabling smooth communication with the electrical grid. The photovoltaic panels produce electricity throughout the day, and being connected to the utility grid guarantees a steady supply of power at night. A key component of this system is net metering, also known as net billing, in which the utility company gives energy credits if the system produces more electricity than is used.

Electricity bills are greatly decreased as a result, and the system owner may even see an increase in profits. It is crucial to remember that every utility network is subject to different rules and guidelines Overall, the grid-connected technology guarantees effective energy utilization, avoiding excessive waste of electricity (Abo-Khalil et al., 2023; Sreedevi et al., 2016).

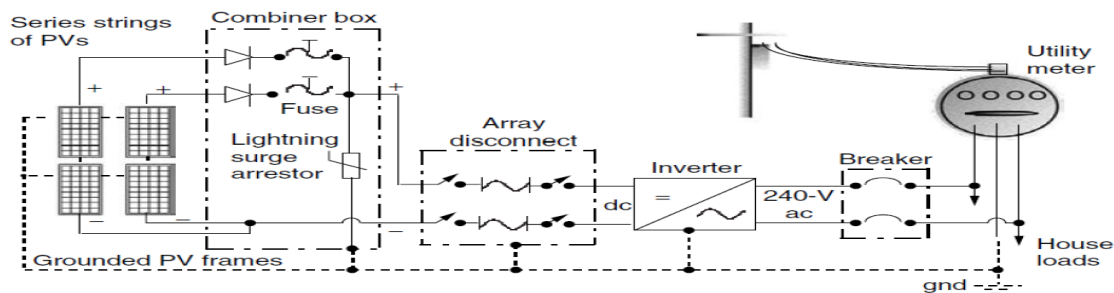

Fig. (2.3): Configuration for Grid-connected system (ee.unlv.edu, n.d).

2.2.3 Comparison of off-grid and grid-connected solar systems:

The location, energy requirements, and financial constraints should all be taken into account when choosing between an off-grid and grid-connected solar system. For cities with dependable grid connectivity and communities looking to profit economically from net metering, grid-connected solutions are perfect. Off-grid solutions, on the other hand, offer energy independence and are appropriate for isolated areas or those who value independence. Knowing the main distinctions between these systems will help you make wise choices that will meet your energy requirements and long-term objectives. The benefits and drawbacks of various methods are contrasted in Table (2.1) (Adebanji et al., 2021).

Tabel (2.1): Comparison of off-grid and grid-connected solar systems.

Elements of comparison	Grid connected	Off Grid
Initial cost	Lower cost	Higher expense because it needs to be charged and discharged, as well as batteries must be purchased and maintained.
Maintenance	Inverter maintenance operations	It needs major battery maintenance.
Reliability	It relies on the utility network	Works independently
Environmental impact	Minimal environmental impacts	a substantial effect on the environment brought on by batteries and how they are disposed of.
Duration of use	Long-term	Limited by battery life
Possibility of expansion	the project can be easily expanded by increasing the photovoltaic panels	It requires a larger budget to purchase additional batteries.

2.2.4 Photovoltaic system components

1) Photovoltaic modules

Crystalline silicon (c-Si), which can be either monocrystalline or polycrystalline, is used to make the majority of solar panels. In recent years, 95% of silicon used in solar modules worldwide has been crystalline silicon. Additionally, there are various varieties on the market that are constructed of amorphous silicon and thin films like CdTe and CIGS. (a-Si) (eia.gov,2015)

Knowing these units' efficiency is the key consideration when selecting them. Recent advancements in thin-film solar cell technology have resulted in single-junction GsAs cells with an efficiency of 29.1% and multi-junction cells with an efficiency of 47.6% by 2023 (IEA Photovoltaic Power Systems Programme,2023).

2) Inverters

It is the main component that converts DC (direct current) to AC (alternating current). When choosing from the several types available, consider the inverters' excellent frequencies, high efficiency, compatibility with the accompanying firm, and the MPPT feature, which tracks the system's maximum power point and optimizes benefits. High voltage spots can be monitored via grid-connected converters. MPPT adjusts the system voltage automatically to guarantee that the PV array operates at its maximum output (Ammous, 2016).

3) Instruments for measuring and tracking : (energy meters) are vital for energy regulation and management, delivering important data to enhance energy efficiency. Energy meters facilitate the buying and selling of electricity as well as billing procedures for consumers and companies alike. Energy consumption can be monitored and optimized through the use of energy meters.

4) Fixed and moveable installation structures: composed of stainless steel and aluminum. electrical connectors and cables that can handle both AC and DC currents and are resilient to environmental elements like humidity and heat.

5) Systems for security: It is used for safety and security measures as well as to prevent damage to system components, For example, circuit breakers, surge protectors, and protective fuses (Ammous, 2016; Rakotomananandro,2011).

2.3 Techno-economic assessment of PV systems:

In order to have a clear picture of investment in this area, many studies have examined the evaluation of power plants using various scales and tools, and they have connected energy production to economy and environment .The technical-economic assessment of Uganda's power plant performance from 2010 to 2021 shows that, in addition to being lucrative, hydro, solar PV, thermal, and cogeneration plants also employ locals rather than foreigners and offer data for improving environmental sustainability and efficiency (Akankunda et al.,2024).an average of 3,222 MWh/yr of electricity were generated annually by a 10.0 MW grid-connected photovoltaic solar power plant in Benin, which supplied electricity to around 131,920 people. The system's power factor is 15.1%, and its performance ratio is 67.3%. Energy expenses per kilowatt-hour range from 0.110 USD to 0.125 USD on a levelized basis. In addition to infrastructure development and government backing making utility-scale photovoltaic solar systems more economically viable, the study suggests that legislation be put into place to accelerate the adoption of renewable energy sources. (Akpahou et al., 2023) study focuses on the best regional solar power tactics while investigating the installation of photovoltaic energy

systems at the Al-Abrar Mosque in Saudi Arabia. In order to outline a road towards net zero billing for the mosque's energy requirements, it incorporates technical assessments, economic analysis, and net metering and net billing scenarios. With payback periods of 7.9 years and 87 years for Scenarios I and II, respectively, the study shows that net metering is the best option for energy efficiency (Alaboodi&Alharbi,2024). The cost efficacy of grid-connected solar energy systems was investigated in a study that focused on three scenarios in Algeria: increasing photovoltaic power generation, reaching net zero monthly electricity usage, and lowering energy costs. This system can reduce carbon dioxide emissions by 17%, eliminate electricity expenditures, and create 23,002 USD in revenue annually, according to the research (Berkani et al., 2024). The results of a study on the establishment of a 1MW photovoltaic power station at the University of Malaysia Pahang revealed that the system reduces carbon dioxide emissions by 818.61 tons while producing about 1390 MWh of electricity yearly (Kaliakparova et al.,2020) .The economic viability of a 1.4 kW photovoltaic station was examined in an Egyptian study, which found that the average annual power generation is 2507.69 kWh/year, with a 6.4-year payback period (Balat et al.,2024). Photovoltaic solar energy systems were used to study the technical and economic viability of water pumping and agricultural irrigation systems in Palestine. When compared to diesel, the return on investment for some solar-powered water pumping systems was approximately one year, while for conventional electric pumps it was almost seven years (Ibrik, 2020).

Chapter Three

Methodology

3.1 Study area

Palestine is located between 34.15° and 35.40° east longitude and 29.30° and 33.15° north latitude, that represent its geographical borders. The varied geography and climate of Palestine are depicted in exquisite detail on the map. The country of Palestine occupies 27,000 square kilometers and is bounded to the north by Lebanon and to the east by Jordan and Syria. Because of its advantageous position, it has strong trading ties with nearby areas. Palestine's natural harbor, which connects Europe, Asia, and Africa, is conveniently located along the Mediterranean Sea.

Particularly in the northern parts of Palestine, the Mediterranean Sea has had a major influence on the climate's variety, which is impacted by western winds that accompany air depressions. Although Palestine has an appropriate temperature in comparison to the Middle East, the climates of the southern and northern regions, as well as the coastal plains and marshes, differ significantly, the location has a significant influence on the climate of Palestine due to the effects of the Jordanian Sahara, the Sinai Desert, and the eastern Mediterranean Sea coast. Thus, it is exposed to sun radiation and is also susceptible to desert and sea impacts Palestine's historical, geographical, highlights the complexity and interrelation of the components that have shaped its status as an issue of international attention over the millennia. The globe has seen significant political and religious transformations, with Palestine in the center because to its strategic location and deep religious significance. Palestine's major cities and inhabited areas are connected by a system of incredibly congested roadways. Significant openness is necessary for the effective implementation of a power structures that is centered on solar energy. The best location for photovoltaic (PV) systems, taking geological factors into account, would be on gently sloping terrain facing south, in places with few natural sources of pollution, such sand or underdeveloped access. In the eastern half of the Gaza Strip and in the western and eastern parts of the West Bank, these good conditions exist.



Fig. (3.1): Map of West Bank and Gaza. State of Palestine, 2025).

3.2 Bani Na'em location

Bani Na'eem is an ancient Palestinian town located in the Hebron Governorate, about 7 kilometers east of the city of Hebron. It is distinguished by its elevated geographical location, which offers a beautiful view of the surrounding areas. The town is considered one of the important historical towns in Palestine, it borders with the towns of Sa'ir and Al-Shuyukh to the north, the city of Hebron to the west, the Masafar region to the east, and the city of Yatta to the south. The town is 970 meters above sea level and spreads throughout a hilly region. With an average annual rainfall of around 369 mm, an average annual temperature around 16 degrees Celsius, and a humidity rate of 61%, its climate is described by warm summers and extremely cold winters.

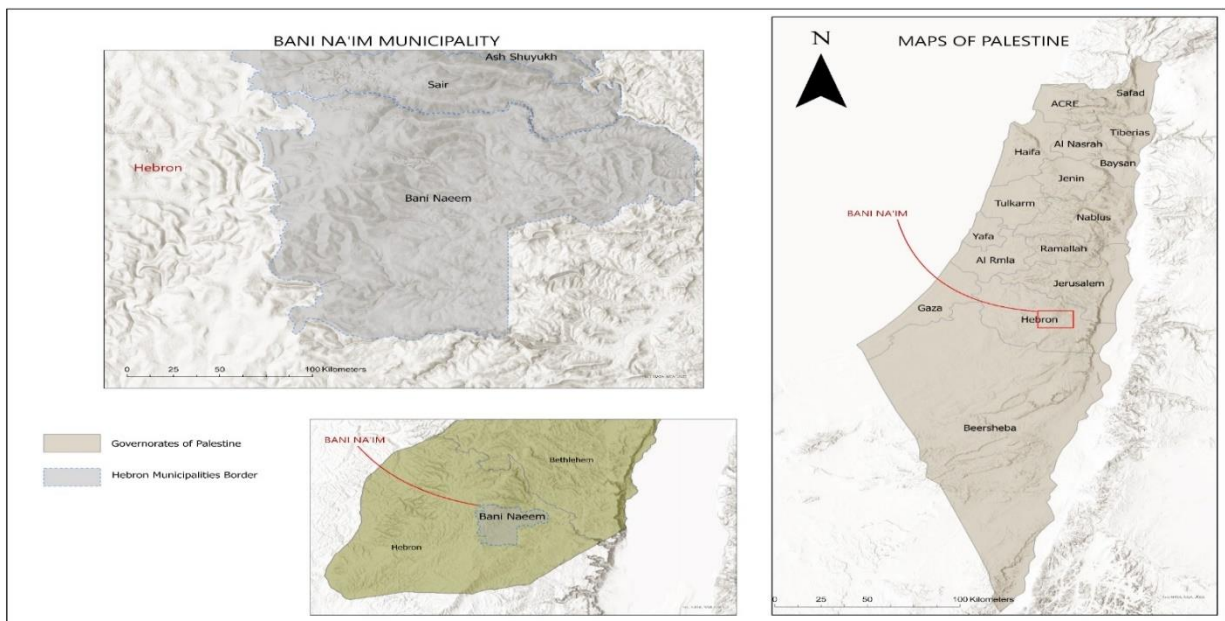

Fig. (3.2): Map of Bani Na'em (Bani Na'im Municipality, 2023).

3.3 The selected school data

The study took place at Bani Na'im Secondary Girls' School, which has a total area of around 910 m². This school belongs to the of the North Hebron Directorate and is situated in the town center, The table (3.1) shows the school data

Table (3.1) School information: Bani Na'eem Secondary Girls'[48].

Location	31.62023148899763, 35.15459634733016
Total area	910 m ²
Number of floors	3
Rise from Sea Level	965 m
school supervisor	governmental

Source: North Hebron Education Directorate (2023).



Fig. (3.3): Bani Na'im Secondary Girls' School (Bani Na'im Municipality, 2023).

3.4 Weather Data:

Environmental factors such as temperature, humidity, and wind significantly affect the efficiency and performance of solar cell systems. High temperatures lead to decreased efficiency, while humidity affects the sustainability of the cells, and wind can have either a positive or negative impact depending on the conditions in general, temperature is considered one of the most important environmental factors affecting the performance of solar cells. Although photovoltaic cells rely on light to generate electricity, an increase in temperature leads to a decrease in the resulting voltage, negatively impacting their efficiency Humidity is also a major factor that can affect the lifespan and efficiency of solar cells, especially in humid environments and coastal areas. Since high humidity can cause the degradation of protective layers in solar cells, leading to moisture seeping into the panels and corrosion of electrical connections and also among the factors affecting solar cells Strong winds that may cause mechanical stresses on the structures supporting solar panels, leading to damage or destruction of some units on the other hand the wind can cool solar cells and reduce their temperature, leading to improved thermal efficiency and increased energy production. The table (3.2) and

fig (3.3) show weather data for the region for the year 2023. (Palestinian Meteorological Department).

Table (3.2) weather data display the region's weather data for 2023(Palestinian Meteorological Department, 2023).

month	Jan	Feb	Mar	Apr	May	Jun	Jul	Aug	Sep	Oct	Nov	Dec
Average hours of sunshine	6.7	7.8	8.4	9.1	11	13.3	13.6	12.9	11.3	9	8	6.7
Average wind speed	6.2	6.4	6.3	5.8	4.7	4.7	4.6	4.4	4	4	4.4	5
Average maximum temperature	10.2	11.5	14.6	19.6	23.6	25.9	27.2	27.2	26	23.2	17.5	12.1
Average minimum temperature	4	4.7	6.5	9.9	13.2	15.8	17	17	15.9	14	9.9	5.6
Average relative humidity	74	72	66	55	48	51	57	60	62	59	64	73

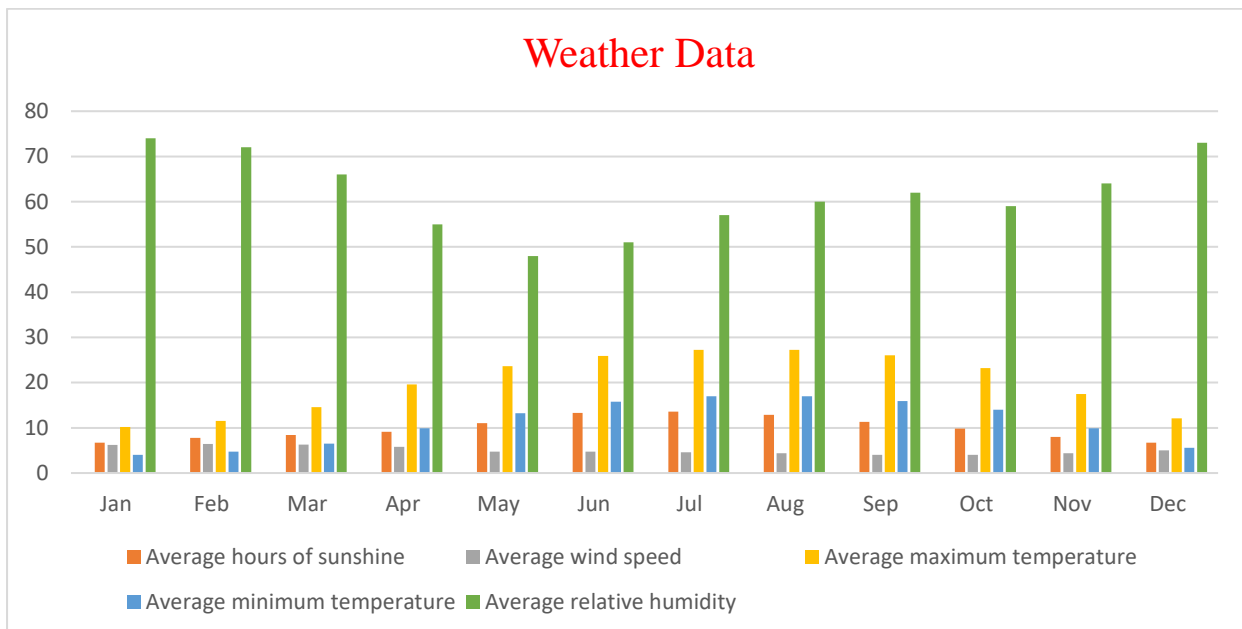

Fig (3.4) displays the region's weather data for 2023.

3.5 Working phases and computer tools

The photovoltaic energy system will be examined using the following software applications:

1. PVsyst software is used to compute the energy output and determine the necessary quantity of solar energy system.
2. The PVCAD program Determine how much PV system is required, figure out how much electricity it will produce, and illustrate solar panels on school rooftops.
3. The Excel application

Write the spread sheets that show the power output, solar radiation intensity, energy consumption, and many graph representations depicted.

On the chosen school for this study, Bani Na'im Secondary School for Girls, information was gathered on its area, location, and annual power usage.

and using this data to calculate the energy generated by this project, as well as to decide the kind and quantity of solar panels that should be put, using the previously described modeling tools. figuring out the overall cost of the school's solar energy project and researching the project's anticipated payback period.

Chapter Four

Results and Discussion

4.1 Introduction The purpose of this study is to assess the viability of installing solar energy systems in one of the Palestinian schools and to offer suggestions for the schools' use of solar energy by making the best use of the vacant rooftops. This is particularly important given the political and economic turmoil that Palestine is currently experiencing, the volatility of fuel prices, and the significant reliance on Israeli electricity import. This study focused on the Bani Na'im Secondary School for Girls, which is connected to the North Hebron Directorate. For a whole year, exact monthly energy usage statistics and bill amounts were collected from Bani Naim Municipality. Subsequently, a virtual solar system was constructed on the school's roof using the PV Syst simulation program. This was done by utilizing local geographic data and environmental factors, considering the best use of the school's roof, comparing the productivity of the solar panels with the electricity consumption over a year, and figuring out the total system costs and the project's payback period. In this chapter, we shall explain this.

4.2 PV systems and revenues: Project design and construction utilizing the PVsyst software will be covered in this part, along with a comparison of the outcomes with the monthly consumption of schools and the computation of the projects' payback period and revenues.

4.2.1) Electricity consumption the school's yearly power usage and monthly bill amounts during a one-year period are depicted in Table (4.1) and "Figure (4.1)". The system capacity required to satisfy the needs of the school and the project's financial expenses will be determined using this data. table 4.1: Electricity consumption and financial cost (kWh and NIS) for Bani Na'im Secondary Girls' School.

Month	The consumption value	The bill value (NIS)
Jan-23	1240	729
Feb-23	2203	1288
Mar-23	751	446
Apr-23	751	446
May-23	100	68
Jun-23	150	97
Jul-23	335	204
Aug-23	600	358
Sep-23	1000	590
Oct-23	1346	791
Nov-23	234	146
Dec-23	800	474
Annual total	9510	5637

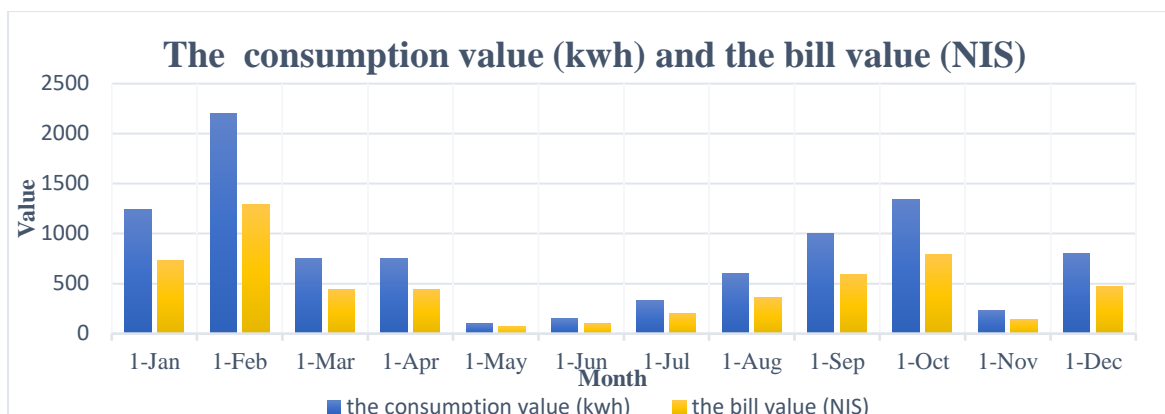

Fig:(4.1): Electricity consumption and financial cost (kWh and NIS) for Bani Na'im Secondary Girls' School.

4.2.2) Specifications of Bani Naeem Secondary School for Girls:The data on the school shown in Table 4.3 was gathered according to the Bani Naim Municipality and the North Hebron Directorate.

Table 4.2: Specifications of Bani Naeem Secondary School for Girls.

Type of building	High school for female students
Owner of building	The Ministry of Education/Directorate of Northern Hebron
The surface area of the school	910 m ²
The monthly bill ranges	(68-1288) NIS
Location	Palestine/ Hebron/Bani Na'im

4.2.3) Values of Monthly Global Solar Radiation in Bani Naim

Hebron-Bani Naim's average daily sunlight hours and monthly global solar radiation are displayed in Table (4.3).

Table 4.3: Monthly global solar insolation at Bani Naeem.

Month	Solar insolation (KWh/m ²)
January	6.7
February	7.8
March	8.4
April	9.1
May	11
June	13.3
July	13.6
August	12.9
September	11.3
October	9.8
November	8
December	6.7
Total /year	118.6
Average insolation	9.88

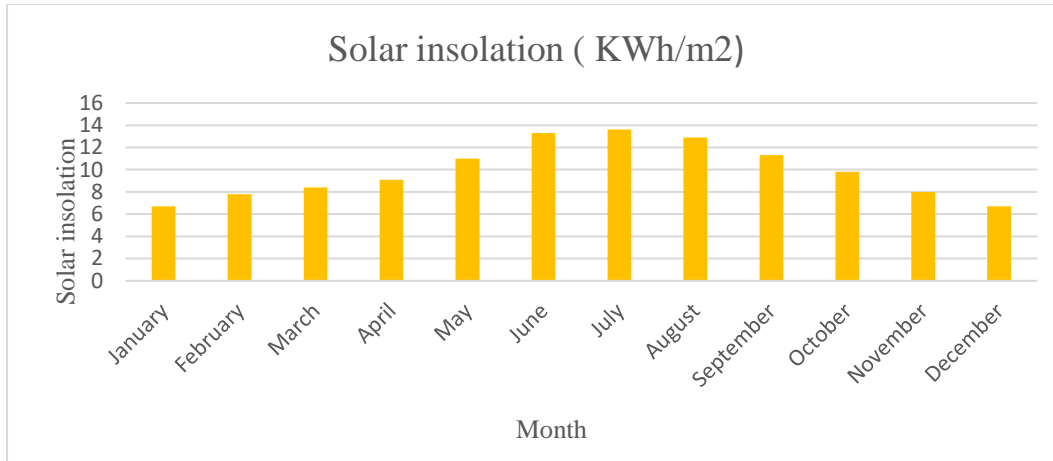

Fig. (4.2): Solar insolation (KWh/m²) in Bani Naeem.

According to the professional software, these values represent the average sun radiation. According to the PVsyst software, Bani Naim's average monthly solar radiation is 9.88 kWh/m².

4.2.4) PV systems and revenues.

A) System Details:

The PVsyst program takes certain data on the location where the solar system is to be put in including the construction site and the construction drawing (AutoCAD for the building). Table (4.4) displays the data that was entered into the PVsyst program.

The information supplied for Bani Naim Secondary School for Girls in PVsyst is displayed in the table (4.4).

Table (4.4) information entered into PVsyst software for Bani Naeem Secondary School for Girls.

Coordinates	31.517054442756372, 35.163045742121604
Altitude	965 m
Azimuth Angle	2°
Tilt Angle	20°

B) The photovoltaic solar module specifications

The features of the grid inverter and solar cell that are employed in the system. However, Tables (4.5) and (4.6) show the features of the grid inverter and solar cell that were employed in the system. When installing a photovoltaic system, the system characteristics are used to determine the system capacity, the minimum and maximum number of cells that can be connected in parallel and series, the resulting voltage and current, and a comparison with the loads that the inverter can manage.

The photovoltaic solar module specifications for Bani Naim Secondary School for Girls are listed in Table (4.5).

The specification of solar PV modules	
Number of panels	189
Module area	494 m ²
Maximum power (pmax)	550 W
Solar Module type	Trina Solar 550W Bifacial Dual Glass
System capacity	103.95 KWp
The voltage at Maximum Power (Vmpp)	31.8
Current at Maximum Power (Impp)	17.29
Open Circuit Voltage (Voc)	38.1
Short Circuit Current (Isc)	18.39
Panel Efficiency (%)	21.0
Maximum system voltage	1500V DC
Cell Type	Mono - Crystalline
Panel dimension (m)	2.384×1.096×0.035 m
Panel area (m ²)	2.613 m ²
Panel weight (Kg)	32.6 kg
Operating Temperature C	-40~+85°C

Table (4.6): Characteristics of the Inverter for Bani Naim Secondary School for Girls.

Characteristics of the Inverter for Bani Naeem Secondary School for Girls	
System capacity	104 kw
Manufacturer	Huawei
(ABB Solar inverters) Type code	SUN2000-100KTL-M1-400V _{ac}
Maximum Efficiency	98.8%
Input (DC)	
Absolute Maximum Input voltage (Vmax, ab)	1100 V
Modules	9 string × 21 In sereis
MPP Input DC Voltage Range(VMPPT, min)-(VMPPT,MAX)	200 V ~ 1,000V
Maximum DC Input Current for each MPPT(Idc, max) /MPPT	29 A
Maximum Short Circuit Current for each MPPT(ISC)	40 A
Output (AC)	
Rated AC Output voltage(Vacr)	400 V
Maximum AC Output current(Iac, max)	160.4 A
Rated output Frequency (Fr)	50 Hz / 60Hz
General data	
Dimension	1,035 x 700 x 365mm
Weight	90 kg
Operating temperature range	-25°C ~ 60°C

Table (4.7) Inverter String for Bani Naeem Secondary School for Girls.

MPPT	String	VMPPT (V)	Idc (A)
MPPT(1)	21 Module	$21 \times 38.1 = 800.1 \text{ V}$ $V_{(oc)} = 800.1 \text{ V}$ For each Module	I=18.39 A
MPPT(2)	21 Module		
MPPT(3)	21 Module		
MPPT(4)	21 Module		
MPPT(5)	21 Module		
MPPT(6)	21 Module		
MPPT(7)	21 Module		
MPPT(8)	21 Module		
MPPT(9)	21 Module		
Number of the Module = $9 \times 21 = 189$			

The figures (4.3) and (4.4) show the distribution of photovoltaic panels on the roof of Bani Naim Secondary School for Girls.

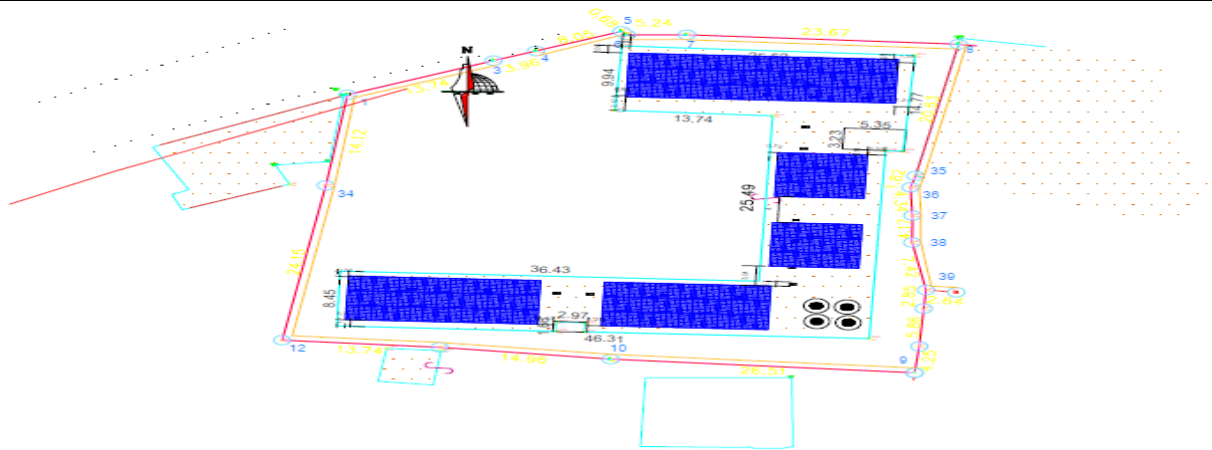

Fig (4.3) distribution of photovoltaic panels on the roof of Bani Naim Secondary School for Girls.

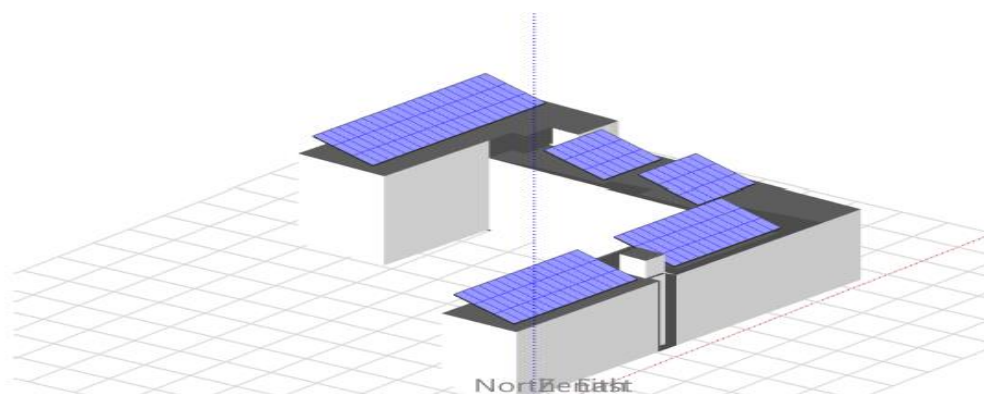

Fig (4.4) shows a perspective of the Bani Naim Secondary School for Girls. roof, including the PV field and surrounding shading.

C)Energy output and Calculate revenues and payback period for the project.

Table (4.8) Monthly AC Production for Bani Naeem Secondary School for Girls.

Month	Monthly AC Production(Kwh)
Jan	11419
Feb	11376
Mar	15035
Apr	16316
May	17637
Jun	18560
Jul	17868
Aug	17341
Sep	15489
Oct	13382
Nov	11233
Dec	10442
Annual total	176098

According to table (4.8) and figure (4.5), the yearly energy production using the PVsyst program on the roof of Bani Naeem Secondary School for Girls (theoretically).

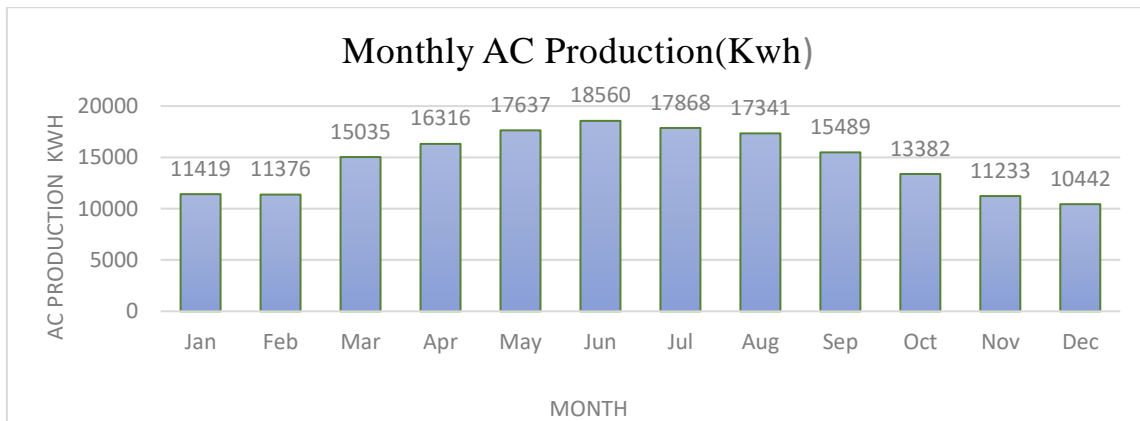

Fig.(4.5) Monthly AC Production for Bani Naeem Secondary School for Girls.

Fig (4.6) provides explanations on the monthly power use and the system's monthly generation on the school roof.

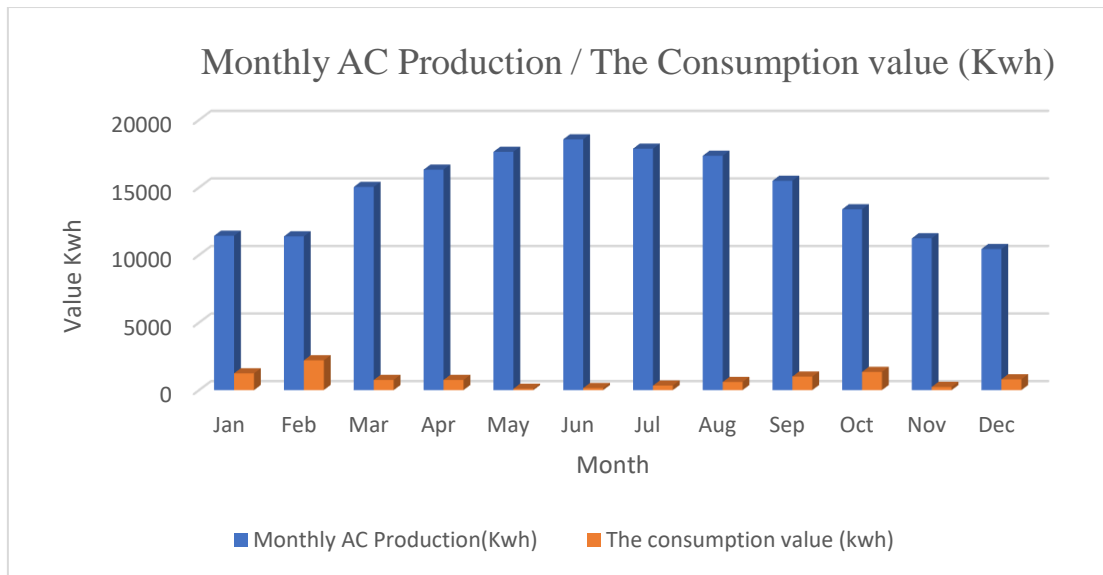

Fig (4.6) Monthly AC Production / Consumption Value (KWh) Bani Naim Secondary School for Girls.

According to the findings in Figure (4.6) there is a significant disparity between production and consumption. This is because Palestinian schools lack energy-intensive electrical systems like heating and cooling systems because the country's moderate autumn, spring, and summer temperatures eliminate the need to cooling systems in schools.

Table (4.9) Monthly AC surplus value (KWh)for Bani Naeem Secondary School for Girls.

Month	The surplus AC value (KWh)
Jan	10179
Feb	9173
Mar	14284
Apr	15565
May	17537
Jun	18410
Jul	17533
Aug	16741
Sep	14489
Oct	12036
Nov	10999
Dec	9642
Total	166588

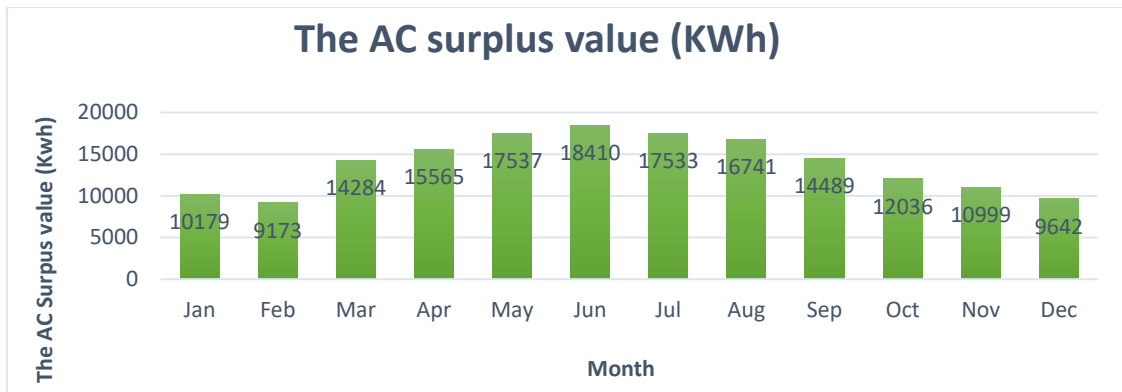

Fig (4.7) Monthly AC surplus value (KWh)for Bani Naim Secondary School for Girls.

D) Project cost calculation:

$$\begin{aligned} \text{Annual revenue} &= \text{The AC surplus value (KWh)} \times \text{price of a kilowatt hour (1 Kwh)} \\ &= 166588 \times 0.58 \\ &= 96621.04 \text{ NIS} \end{aligned}$$

$$\begin{aligned} \text{The total cost of the project} &= \text{cell capacity} \times \text{number of cells} \times \text{Kilowatt price in NIS} \\ &= 0.55 \times 189 \times 2880 \\ &= 299376 \text{ NIS} \end{aligned}$$

If the project is expected to last 20 years, Figure (4.8) shows that it will bring in up 1932420.8 NIS.

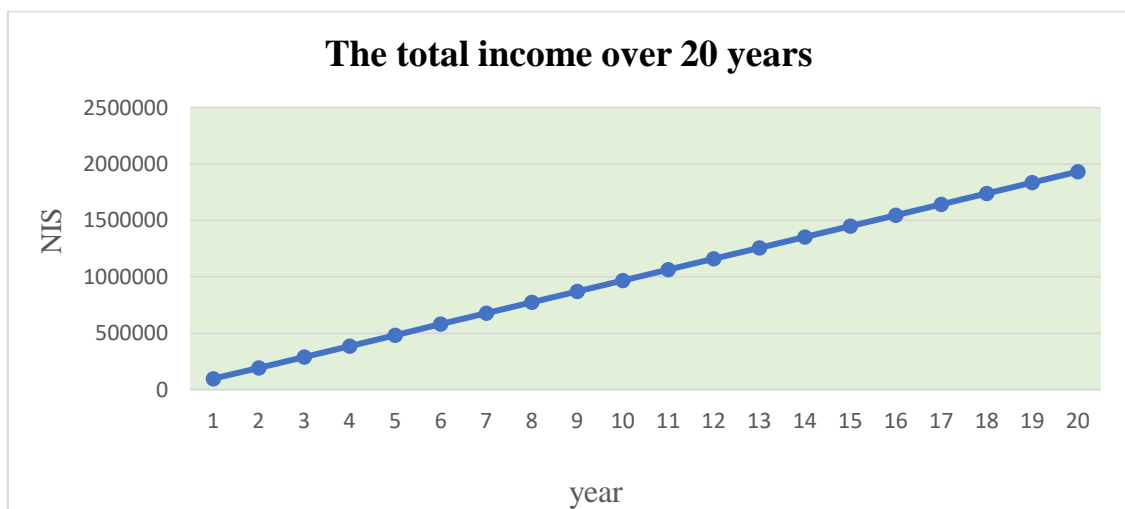

Fig. (4.8) Total income over 20 years Bani Naim Secondary School for Girls.

$$\text{Payback period} = \text{Total income over 20 years} / \text{The total cost of the project}$$

$$\text{Payback period} = 1932420.8 / 299376$$

$$\text{Payback period} = 6.45 \text{ year}$$

Chapter Five

Conclusions and Future work

5.1 Conclusions: The main objective of this study is to evaluate the efficiency and effectiveness of using photovoltaic solar energy systems designed and installed on building rooftops in Palestine to satisfy energy demands. Given the many obstacles Palestine's energy industry faces, these rooftops represent a valuable resource that may be used to produce renewable energy. One of the most important of these issues is the restricted area for the installation of photovoltaic solar systems, which is made worse by the occupation's policies, which take the form of a number of restrictive practices and measures that severely limit the potential for making use of the available spaces. The significance of solar energy system design in Palestine extends beyond the spatial constraints. Investing in solar energy is essential for a number of logistical and financial reasons. The most notable of them is the ongoing increase in power rates, which is mostly caused by rising fuel prices worldwide and puts a growing financial strain on both individuals and organizations. In addition, the Israeli electrical Company's regular power outages have resulted in a serious electrical crisis in Palestine, which has left the West Bank and Gaza Strip severely short on energy supplies. The situation is particularly bad in the Gaza Strip, where the enforced embargo has caused Palestinians to endure years of continuous power shortages. Every element is immediately impacted by these interruptions. This study addressed the design of photovoltaic solar energy systems on the roof of Bani Naim Secondary Girls' School, a public school, with the aim of highlighting the importance, benefits, and effectiveness of utilizing building rooftops to create renewable energy generation systems. The roof of this school was specifically chosen because it is an underutilized space, making it an ideal location for establishing a solar energy system that can contribute to improving electricity consumption efficiency and reducing reliance on the public grid. Additionally, the school sector is characterized by a low electricity consumption rate compared to other buildings, as educational institutions do not typically use equipment and devices that consume large amounts of energy. Furthermore, the school's operating hours are limited to a specific number of hours each day. Moreover, the school closes its doors for approximately 180 days annually, significantly reducing its energy consumption during that period. Therefore, installing solar energy systems on school rooftops not only helps meet their energy needs during operational days but can also produce an electrical surplus that can be stored or fed into the public grid for use during periods of need. Using information on the system's area, location, and technical features of the solar panels and equipment, the PVsyst program was utilized in this study to model and develop the photovoltaic solar energy system. In addition to examining the monthly energy output, this application determined the amount of electrical energy that the project might produce yearly,

which aids in assessing the system's performance over the course of the year. Using the data collected, which displays the monthly and annual consumption rates, the system's efficiency was further assessed by comparing the quantity of energy generated to the actual amount of power used in the school.

Table (4.10) summary of the results.

school	Bani Naim Secondary School for Girls
System area (m ²)	494
System capacity(kw)	103.95
Number of panels	189
Annual consumption (Kwh)	9510
Annual production (Kwh)	176098
Annually surplus (Kwh)	166588
Annual revenue(income)	96621.04
The total cost of the project (NIS)	299376
Total income over 20 years (NIS)	1932920.8
Payback period(year)	6.45

5.2 Future work

One of the basic elements of daily living and economic progress is the energy business. The development and expansion of renewable energy sources is therefore essential, especially in Palestine, which frequently faces energy crises due to its heavy reliance on imported power. Because building rooftops, whether those of private residences or public buildings, are often underutilized, energy and planning experts should do everything in their power to expand research that emphasizes the importance of implementing solar energy projects.

This study illustrates the significance of spreading the concept of developing and designing rooftop systems generally in Palestine by examining the photovoltaic systems on the school roofs and proving their efficacy. Additionally, the high and unique productivity of these projects in Palestine adds to their significance.

In conclusion, a number of suggestions that emphasize the significance of these three initiatives must be made when they are implemented:

- 1.The significance of installing photovoltaic energy projects on building rooftops as an alternative energy source should be clarified by experts and researchers in the fields of renewable energy and planning. These studies and research should then be distributed to the appropriate authorities, governmental organizations, and the private sector.
2. By encouraging private sector and electrical firms to invest in these projects, the government should pass laws, rules, and legislation that promote the use of building rooftops in Palestine and the installation of solar energy systems.
3. Raising awareness of the value of renewable energy in schools, colleges, and other communication channels will encourage and motivate people to convert to solar energy projects because they reduce pollution and the use of fossil fuels, which increase risks and environmental pollutants.
- 4.Prior to beginning the process of implementation, you should give serious and well-thought-out consideration to the design of the locations where solar energy projects are going to be developed in order to achieve photovoltaic systems that are both efficient and of good quality.

References

- “Boosting Green Power Generation through Noor Palestine”, Palestine Investment Fund, 2018.
- “Electric Utility Management Project. Construction of KV 161/33 Electricity Sub-Stations, Environmental and Social Management Plan”, Palestinian Energy and Natural Resources Authority, Ramallah Palestine, 2014. Available: <http://www.petl.ps/doc/ESM%20Nablus.pdf>.
- Abo-Khalil, A. G., Sayed, K., Radwan, A., & El-Sharkawy, I. A. (2023). Analysis of the PV system sizing and economic feasibility study in a grid-connected PV system. *Case Studies in Thermal Engineering*, 45, 102903.
- Abualkhair, A. (2007). Electricity sector in the Palestinian territories: Which priorities for development and peace? *Energy policy*, 35(4), 2209-2230.
- Adebajji, B., Atoki, O., Fasina, T., Adetan, O., & Abe, A. (2021). Comparative study of off-grid and grid-connected hybrid power system: issues, future prospects and policy framework. *Indonesian Journal of Electrical Engineering and Computer Science*, 22(2), 752-759.
- Akankunda, B., Adaramola, M. S., Nkundabanyanga, S. K., Kaawaase Kigongo, T., & Mukisa, N. (2024). Techno-economic performance assessment of selected power plants in Uganda. *International Journal of Sustainable Energy*, 43(1), 2350980.
- Akpahou, R., Odoi-Yorke, F., & Osei, L. K. (2023). Techno-economic analysis of a utility-scale grid-tied solar photovoltaic system in Benin republic. *Cleaner Engineering and Technology*, 13, 100633.
- Alaboodi, A. S., & Alharbi, S. J. (2024). A Study on the Techno-Economics Feasibility of a 19.38 KWp Rooftop Solar Photovoltaic System at Al-Abrar Mosque, Saudi Arabia. *Energies*, 17(10), 2325.
- Alboteanu, I. L., Ivanov, S., & Manolea, G. (2008). Modelling and simulation of a stand-alone photovoltaic system. *Faculty for Electromechanical, Environment and Industrial Informatics Engineering, University of Craiova*, 107.
- Alsamamra, H., & Ajlouni, E. (2019). A Review of Solar Energy Prospects in Palestine," *American Journal of Modern Energy*, vol. 5, no. 3, pp. 49-62.
- Alsamamra, H., & Shoqeir, J. (2021). Solar photovoltaic systems on public schools buildings: a case study in Palestine. *American Journal of Electrical Power and Energy Systems*, 2021, 10, 13-20.
- Ates, A. M., & Salmanoğlu, F. (2017). A Project That Provides Electricity from Solar Energy for Vocational School Campus. In *Solaris 2017 Conference Proceedings* (pp. 1-6).
- Balat, A. E., Elshebiny, M. E., El-shenawy, E. T., Hegazy, A. H., & Nasef, A. F. (2024). Techno-Economic Analysis of Grid-Connected PV Power Plants in Different Zones of Egypt. *ERJ. Engineering Research Journal*, 47(4), 473-484.
- Bani Na'im Municipality. Hebron, Palestine /bani_naim_mun@yahoo.com.
- Berkani, L., Nadjemi, O., Nacer, S., Fodhil, F., Nacer, T., & Alliche, Z. (2024). Techno-Economic Assessment of Small Industrial Facilities Powered by Grid-Connected Photovoltaic Systems in Algeria. *Process Integration and Optimization for Sustainability*, 8(5), 1581-1601.

- Boero, R., Backhaus, S. N., & Edwards, B. K. (2016). The microeconomics of residential photovoltaics: Tariffs, network operation and maintenance, and ancillary services in distribution-level electricity markets. *Solar Energy*, 140, 188-198.
- Carvajal-Romo, G., Valderrama-Mendoza, M., Rodríguez-Urrego, D., & Rodríguez-Urrego, L. (2019). Assessment of solar and wind energy potential in La Guajira, Colombia: Current status, and future prospects. *Sustainable Energy Technologies and Assessments*, 36, 100531.
- connected PV power systems in five climate zones, China. *Energy*, 165, 1352-1369.
- developing grid-connected photovoltaic plants in the southern coast of Iran. *Energy*, 156, 17-31.
- Electric generator capacity factors vary widely around the world". *eia.gov*. 6 September 2015. Retrieved 17 June 2018.
- Falinirina F. Rakotomananandro "Study of Photovoltaic System" Master thesis presented to the Ohio State University, 2011.
- Haffaf, A., Lakdja, F., Meziane, R., & Abdeslam, D. O. (2020). Promotion and effective integration of school rooftop PVsystem based load management activities: A case study. *International Journal of Sustainable Development and Planning*, 15(4), 501-511.
- Hamed, T. A., Flamm, H., & Azraq, M. (2012). Renewable energy in the Palestinian Territories: Opportunities and challenges. *Renewable and Sustainable Energy Reviews*, 16(1), 1082-1088.
- <http://www.ee.unlv.edu/~eebag/Photovoltaic%20Systems%20II.pdf>.
- Ibrik, I. H. (2020). Techno-economic assessment of on-grid solar PV system in
- Ibrik, I., & Hashaika, F. (2019). Techno-Economic Impact of Grid-Connected Rooftop Solar PV System for Schools in Palestine: A Case Study of Three Schools. *International Journal of Energy Economics and Policy*, 9(3), 291-300.
- Juaidi, A., Montoya, F. G., Ibrik, I. H., & Manzano-Agugliaro, F. (2016). An overview of renewable energy potential in Palestine. *Renewable and Sustainable Energy Reviews*, 65, 943-960.
- Kaliakparova, G. S., Gridneva, Y. E., Assanova, S. S., Sauranbay, S. B., & Saparbayev, A. D. (2020). International economic cooperation of Central Asian countries on energy efficiency and use of renewable energy sources. *International Journal of Energy Economics and Policy*, 10(5), 539-545.
- Kermadi, M., & Berkouk, E. M. (2017). Artificial intelligence-based maximum power
- Khairi, N. H. M., Akimoto, Y., & Okajima, K. (2022). Suitability of rooftop solar photovoltaic at educational building towards energy sustainability in Malaysia. *Sustainable Horizons*, 4, 100032.
- Khatib, T., Bazyan, A., Assi, H., & Malhis, S. (2021). Palestine energy policy for photovoltaic generation: Current status and what should be next? *Sustainability*, 13(5), 2996.
- Kishore, P., & Kisiel, J. (2013). Exploring High School Students' Perceptions of Solar Energy and Solar Cells. *International Journal of Environmental and Science Education*, 8(3), 521-534.
- Leena M. Ammous "Techno-Economic Impact of Using On-Grid and Off-Grid PV Solar Systems in West Bank (Masoud village as a case study) " A thesis presented to the University of An-Najah National University, Nablus, Palestine,2016.
- Li, C., Zhou, D., & Zheng, Y. (2018). Techno-economic comparative study of grid-
- Luque, A., & Hegedus, S. (Eds.). (2011). *Handbook of photovoltaic science and engineering*. John Wiley & Sons.

- Mane, P., Madiwal, S., & Patil, P. (2022, August). OFF Grid PV System with PWM Inverter for Isolated Micro-Grid feeding critical loads. In *2022 IEEE 2nd International Conference on Sustainable Energy and Future Electric Transportation (SeFeT)* (pp. 1-7). IEEE.
- Map of West Bank and Gaza <https://www.google.com>
- Mohammadi, K., Naderi, M., & Saghafifar, M. (2018). Economic feasibility of
- Omar, M. A., & Mahmoud, M. M. (2018). Economic evaluation of residential grid connected PV Systems based on Net-Metering and Feed-in-Tariff schemes in Palestine. *International Journal of Renewable Energy Research*, 8(4), 16-27.
- OSLO, B. (1995). Israeli-Palestinian Interim Agreement on the West Bank and Gaza Strip. Appendix II Annex III Article, 40.
- Ouda, M. J. E. R. (2003). Prospects of Renewable Energy in Gaza Strip. Energy Research Development Center, Islamic University of Gaza, Palestine.
- P.E.R.C, "Renewable energy laws and legislation," Palestinian Electricity Sector Regulatory Council, 2015. [Online]. Available: https://perc.ps/perc/?page_id=85. Palestine. *Cogent Engineering*, 7(1), 1727131.
- Palestinian Meteorological Department <http://www.pmd.ps/viewVisionEng.do>
- point tracking controllers for Photovoltaic systems: Comparative study. *Renewable and*
- Rabi, A., & Ghanen, I. (2016). Pre master plan solar energy production in palestine . Palestinian Environmental NGOs Network.
- Ramadan, M., Alsurakji, I. H., Al-Khalil, Q., & Tobah, M. (2023). Powering Agricultural Pumps by Solar Photovoltaic System–Case Study from Palestine. *An-Najah University Journal for Research-A (Natural Sciences)*, 38(2), 85-90.
- Snapshot of Global PV Markets 2023, IEA Photovoltaic Power Systems Programme..
- Sreedevi, J., Ashwin, N., & Raju, M. N. (2016, December). A study on grid connected PV system. In *2016 National Power Systems Conference (NPSC)* (pp. 1-6). IEEE. *Sustainable Energy Reviews*, 69, 369-386.
- Tayeh, R. A., Alsayed, M. F., & Saleh, Y. A. (2021). The potential of sustainable municipal solid waste-to-energy management in the Palestinian Territories. *Journal of Cleaner Production*, 279, 123753.
- Yao, H., & Zhou, Q. (2023). Research status and application of rooftop photovoltaic Generation Systems. *Cleaner Energy Systems*, 5, 100065
- Yoshikawa, K., Kawasaki, H., Yoshida, W., Irie, T., Konishi, K., Nakano, K., ... & Yamamoto, K. (2017). Silicon heterojunction solar cell with interdigitated back contacts for a photoconversion efficiency over 26%. *Nature energy*, 2(5), 1-8.

كفاءة مشاريع الطاقة الشمسية الكهروضوئية على أسطح المدارس في فلسطين: دراسة حالة في بلدة بني نعيم

إعداد:

ايات عيسى أحمد زيدات

إشراف:

د.حسين السامرة

ملخص

نظرا لل صعوبات والعوائق التي تواجهها الدول في قطاع الطاقة، فضلا عن النمو السكاني وارتفاع استهلاك الطاقة، من الضروري الآن اللجوء إلى مصادر الطاقة البديلة، وخاصة مصادر الطاقة المتجددة، والتي تعتبر ضرورية لتلبية الطلبات العالمية وضمان الاستدامة البيئية بسبب استدامتها وتوفرها. يرتبط وضع الطاقة في فلسطين على وجه الخصوص بالقيود البنوية والسياسية والاقتصادية، التي تتطلب الكثير من العمل لحلها. من الضروري الآن إيجاد بديل للوقود الأحفوري ، وقد تبين أن الطاقة الشمسية هي الخيار الأفضل. في فلسطين، يعد خيارا قابلا للتطبيق لتعزيز الاستدامة وأمن الطاقة.

يجب أن تكون المواقع المناسبة لمشاريع الطاقة الشمسية متاحة من أجل الحصول على الطاقة الشمسية استخدام الأسطح شبه الفارغة للمدارس لإنتاج الطاقة من خلال مشاريع الطاقة الشمسية الكهروضوئية هو المكان الذي تطور فيه مفهوم هذه الدراسة. إلى جانب انخفاض استخدام الطاقة ، تغلق المدارس أبوابها لحوالي 180 يوما في السنة ولا تعمل أكثر من سبع ساعات في اليوم. هذا يعزز استخدام هذه المناطق المفتوحة على أسطح المدارس لإنتاج الطاقة الشمسية.

لإجراء تقييم جدوى استخدام أسطح المباني لتوليد الطاقة الشمسية، استخدمت هذه الدراسة برنامج الطاقة الشمسية الكهروضوئية PVSyst لإنشاء نظام كهروضوئي افتراضي على سطح مدرسة بني نعيم الثانوية للبنات. قدرت سعة النظام ب 104 كيلو واط ، بمساحة إجمالية قدرها 494 مترا مربعا ، باستخدام 189 لوحا ، وإنتاج سنوي متوقع يبلغ 176,098 كيلو واط ساعة. ووفقا لشركة الكهرباء الإقليمية، بلغ استهلاك المدرسة 9,510 كيلو واط ساعة، مما أدى إلى فائض سنوي قدره 166,588 كيلو واط ساعة، وبلغ سعر البيع كل عام 96621.04 شيكل. هناك أكثر من 3,075 مدرسة في فلسطين. سيولد المشروع 541 جيجاوات في الساعة عند تنفيذه في هذه المدارس، وسيكلف حوالي 920 مليون شيكل على مدى ست سنوات.